

MAXETA iFA SERIES DC-DC POWER MODULES 48V Input, 9.6V/55A Output, Full Brick

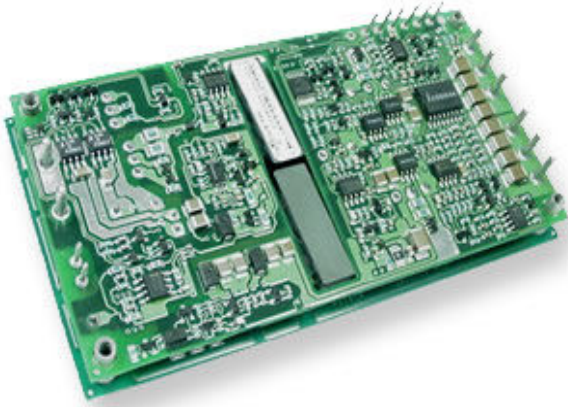

The Maxeta™ Series power modules are ideally suited for extremely high-density distributed power architectures where the demands of voltage and substantial load mandate the creation of a robust local intermediate 9.6Vdc distribution bus. With a typical 92% full load efficiency (93% at 70% load), a power density greater than 95W per cubic inch and a total power and current output capability of 528W and 55A respectively, Maxeta™ Series offers the highest efficiency, power density and usable output power in a full brick package currently available. A wide output voltage trim range, -40% to +10%, remote sensing, isolated remote on/off control, and single wire active current sharing are standard features enhancing versatility.

Standard Features:

- Industry Standard 528W full brick
- Power density: > 95W/cubic inch
- High efficiency: up to 94.5%
- Full load efficiency: 92% at nominal input
- 70% load efficiency: 93% at nominal input
- Up to 528W of output power.
- Metal board design with high usable power 41.5A at 65C, 200LFM, no heat sink
- Meets basic insulation requirements
- Single wire forced current sharing
- Start-up into pre-biased output bus
- Voltage foldback constant current limit
- User selectable on/off (either positive or negative logic)
- Wide output voltage adjustment range
- Auto-recovery protections:
 - Input under and over voltage
 - Current limit
 - Short circuit
 - Thermal limit
- Latched output over-voltage protection
- High reliability open frame, surface mount construction
- Base-plate for improved thermal management
- Constant switching frequency
- Optional 0.110" pin length
- UL 60950 (US and Canada), VDE 0805, CB scheme (IEC950)
- CE Mark (EN60950)
- EMI: CISPR 22 Class A/B with external filters
- US 6,618,274.
- ISO Certified manufacturing facilities

Optional Features:

- Thru-hole PEM studs for ease of clamshell type of heat sink mounting

Data Sheet: Maxeta™ iFA Series

Ordering information:

Product Identifier	Package Size	Platform	Input Voltage	Output Current/Power	Output Units	Main Output Voltage	# Of Outputs		Safety Class	Feature Set
i	F	A	48	055	A	096	V	-	0	00
TDK Innoveta	Full Brick	Standard Maxeta™	36 - 75V	055 – 55	Amps	096 – 9.6V	Single			00 – Standard >00 – See option table

Feature Set	OVP Out Replaces Power Good	Pin Length	PEM Stud Style	Special Code
00	No	0.145"	Threaded	No
01	No	0.110"	Threaded	No
02	Yes	0.145"	Threaded	No
03	Yes	0.110"	Threaded	No
20	No	0.145"	Thru-hole	Yes. No power good, no aux output features

Product Offering:

Code	Input Voltage	Output Voltage	Output Current	Maximum Output Power	Efficiency
iFA48055A096V -000	36V to 75V	9.6V	55A	528W	92%

TDK Innoveta Inc.

3320 Matrix Drive, Suite 100
Richardson, Texas 75082

Phone (877) 498-0099 Toll Free
(469) 916-4747
Fax (877) 498-0143 Toll Free
(214) 239-3101

support@tdkinnoveta.com
<http://www.tdkinnoveta.com>

Mechanical Specification:

Unless otherwise specified, tolerances are: $x.x \pm 0.5$ [0.02], $x.xx$ and $x.xxx \pm 0.25$ [0.010].

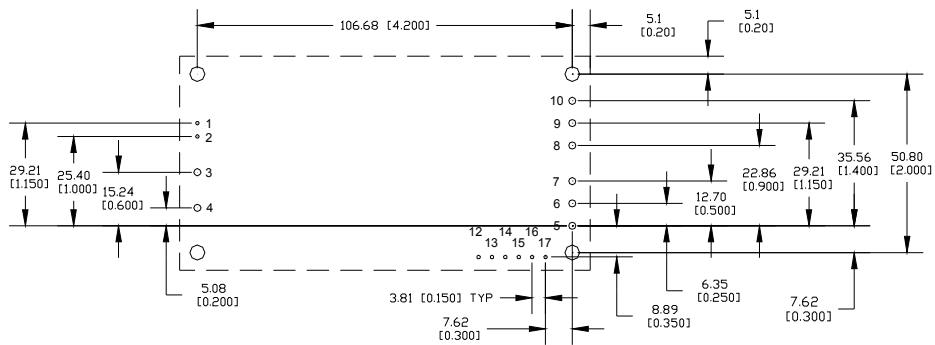
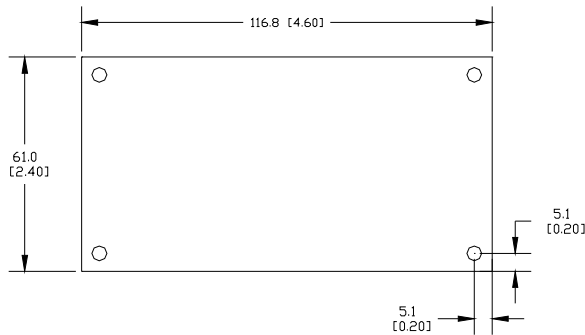
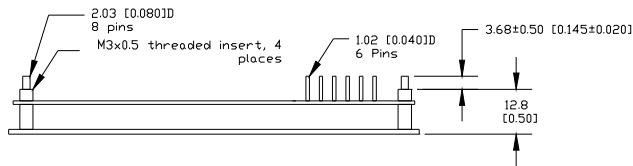
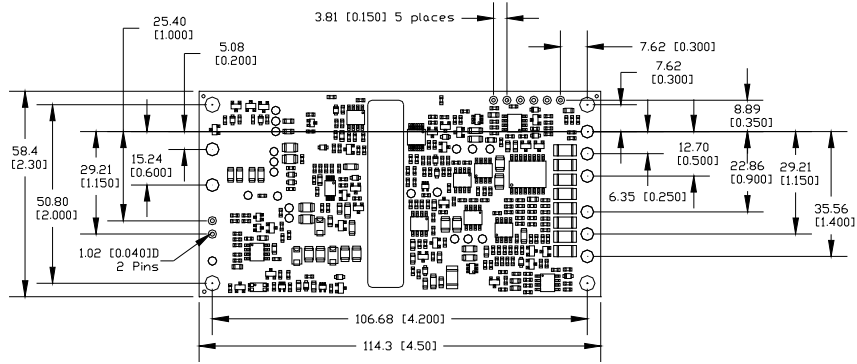

Recommended hole pattern (top view)

Pin Assignment:

PIN	FUNCTION	PIN	FUNCTION	PIN	FUNCTION
1	ON/OFF (+)	7	Vout (-)	13	N/A
2	ON/OFF (-)	8	Vout (+)	14	Load Share
3	Vin (+)	9	Vout (+)	15	TRIM
4	Vin (-)	10	Vout (+)	16	SENSE (+)
5	Vout (-)	11	Not Present	17	SENSE (-)
6	Vout (-)	12	N/A	18	

* Pin base material is copper. The maximum module weight is 250g (8.8 oz).

Heatsink Offering:

Innoveta Part Number	Height	Orientation	Overall Module Height
HS00016	0.50"	Transverse	1.00"
HS00017	1.00"	Transverse	1.50"
HS00020	0.50"	Longitudinal	1.00"
HS00021	1.00"	Longitudinal	1.50"

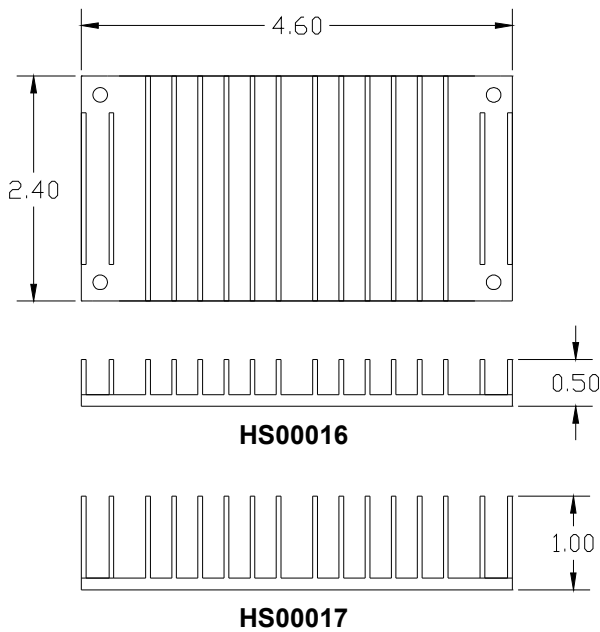

Transverse Heatsinks

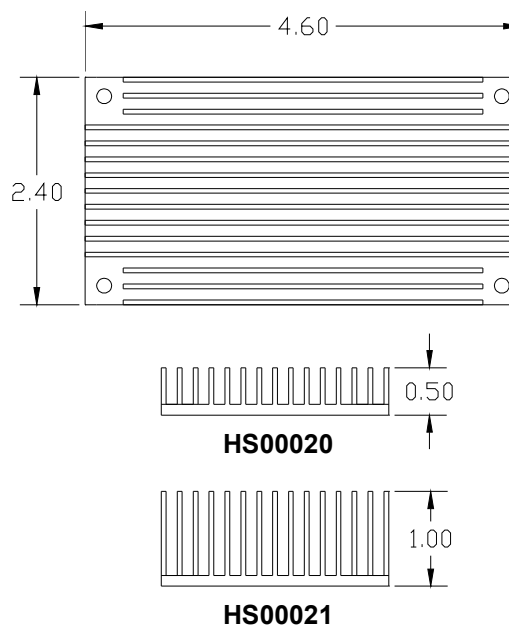

Longitudinal Heatsinks

Absolute Maximum Ratings:

Stress in excess of Absolute Maximum Ratings may cause permanent damage to the device.

Characteristic	Min	Max	Unit	Notes & Conditions
Continuous Input Voltage	-0.5	80	Vdc	
Transient Input Voltage	---	100	Vdc	100mS max.
Isolation Voltage Input to Output Input to Base-plate Output to Base-plate	---	1500 1500 500	Vdc Vdc Vdc	Basic Insulation Basic Insulation Operational Insulation
Storage Temperature	-55	125	°C	
Operating Temperature Range (Tc)	-40	115	°C	Measured at the location specified in the thermal measurement figure; maximum temperature varies with output current and module orientation – see curve in the thermal performance section of the data sheet.

Input Characteristics:

Unless otherwise specified, specifications apply over all rated input voltage, resistive load, and temperature conditions.

Characteristic	Min	Typ	Max	Unit	Notes & Conditions
Operating Input Voltage	36	48	75	Vdc	When $36V \leq V_{in} < 37V$, the modules will continue to operate, but the output voltage regulation may be out of spec at load $\geq 90\%$ of full load
Maximum Input Current	---	16	17*	A	$V_{in} = 0$ to $V_{in,max}$
Input Low End Turn-on Voltage	---	34.2	36	Vdc	
Input Low End Turn-off Voltage	30*	32.2	36	Vdc	
Hysteresis	---	2	---	Vdc	
Input Over-voltage Turn-off Voltage	---	79.5	83*	Vdc	
Input High End Turn-on Voltage	75	78	---	Vdc	
Startup Delay Time from application of input voltage	---	12	---	mS	$V_o = 0$ to $0.1 \cdot V_{o,nom}$; on/off = on, $I_o = I_{o,max}$, $T_c = 25^\circ C$
Startup Delay Time from on/off	---	8	---	mS	$V_{in} = V_{in,nom}$, $I_o = I_{o,max}$, $T_c = 25^\circ C$
Output Voltage Rise Time	---	30	---	mS	$I_o = I_{o,max}$, $V_o = 0.1$ to $0.9 \cdot V_{o,nom}$, $T_c = 25^\circ C$
Inrush Transient	---	---	1	A ² S	
Input Reflected Ripple	---	20	---	mApp	$V_{in} = V_{in,nom}$, $I_o = I_{o,max}$ (0 to 20MHz) See input/output ripple measurement figure; BW = 20 MHz
Input Ripple Rejection	---	41	---	dB	@120Hz

* Engineering Estimate

Caution: The power modules are not internally fused. An external input line fuse with a maximum value of 20A is required. See the Safety Considerations section of the data sheet.

Electrical Data:
iFA48055A096V- 000 through – 0x3: 9.6V, 55A Output

Characteristic	Min	Typ	Max	Unit	Notes & Conditions
Output Voltage Initial Set-point	9.38	9.6	9.82	Vdc	Vin=Vin,nom; Io=Io,max; Tc = 25°C
Output Voltage Tolerance	9.31		9.89	Vdc	Over all rated input voltage, load, and temperature conditions to end of life
Efficiency	---	92	---	%	Vin=Vin,nom; Io=Io,max; Tc = 25°C
Line Regulation	---	2	20	mV	Vin=Vin,min to Vin,max, Io and Tc fixed
Load Regulation	---	2	20	mV	Io=Io,min to Io,max, Vin and Tc fixed
Temperature Regulation	---	25	100*	mV	Tc=Tc,min to Tc,max, Vin and Io fixed
Output Current	10	---	55	A	At loads less than Io,min the module will continue to regulate the output voltage, but the output ripple may increase
Output Current Limiting Threshold	57	62	---	A	Vo = 0.9*Vo,nom, Tc<Tc,max, Tc = 25°C
Short Circuit Current	---	3	---	A	Vo = 0.25V, Tc = 25°C
Output Ripple and Noise Voltage	---	50	100*	mVpp	Vin=48V, Io≥Io,min, Tc = 25°C, with a 0.1μF, a 10μF ceramic, two 220μF low esr aluminum capacitors located 2 inch away. See input & output ripple measurement figure; BW = 20MHz
	---	12	50*	mVrms	
Output Voltage Adjustment Range	60	---	110	%Vo,nom	Po≤Po,max, refer to "Output Voltage Adjustment" figure for Vin,min requirement
Remote Output Voltage Sense Range	---	---	---	Vdc	
Dynamic Response:					
Settling Time to 10% Peak Deviation	---	0.7	---	mS	di/dt = 0.1A/uS, Vin=Vin,nom; Tc = 25°C, load step from 50% to 75% of Io,max. With at least a 10uF ceramic capacitor and a 470uF low esr aluminum or tantalum capacitor across the output terminals.
Peak Voltage Deviation	---	300	---	mV	
Output Voltage Overshoot during Startup	0	0	---	mV	
Switching Frequency	---	110	---	kHz	Fixed
Output Over Voltage Protection	11.1	11.8	12.5	V	
External Load Capacitance	450	---	10,000 **	uF	Minimum ESR > 2mΩ
Isolation Capacitance	---	1000	---	pF	
Isolation Resistance	15	---	---	MΩ	
Load Share Accuracy	-10	---	+10	%	50% to 100% rated load current
Power Good Pin Max Applied Voltage	N/A	N/A	N/A	Vdc	
Auxiliary Output Voltage	N/A	N/A	N/A	Vdc	

* Engineering Estimate

** Contact TDK Innoveta for applications that require additional capacitance or capacitors with very low esr

Electrical Characteristics:

iFA48055A096V- 000 through – 0x3: 9.6V, 55A Output

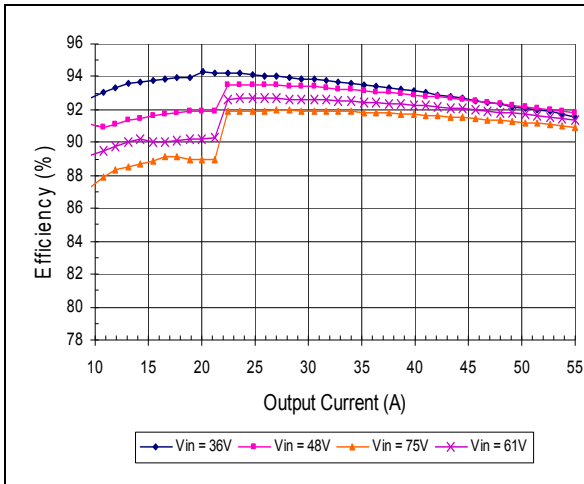

Typical Efficiency vs. Input Voltage and Load (use test socket)

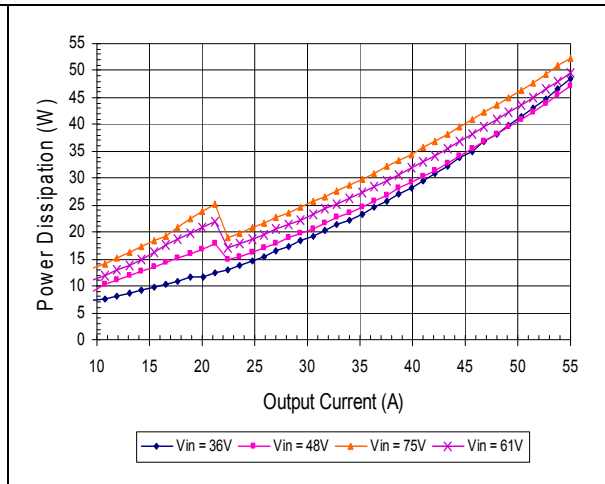

Typical Power Dissipation vs. Input Voltage and Load at Ta=25 °C

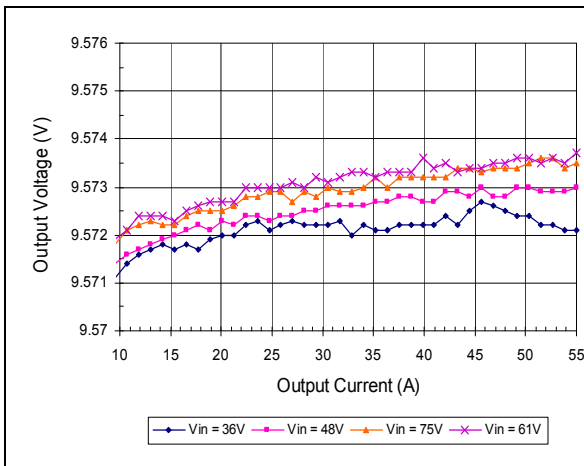

Typical Output Voltage vs. Load Current (use test socket)

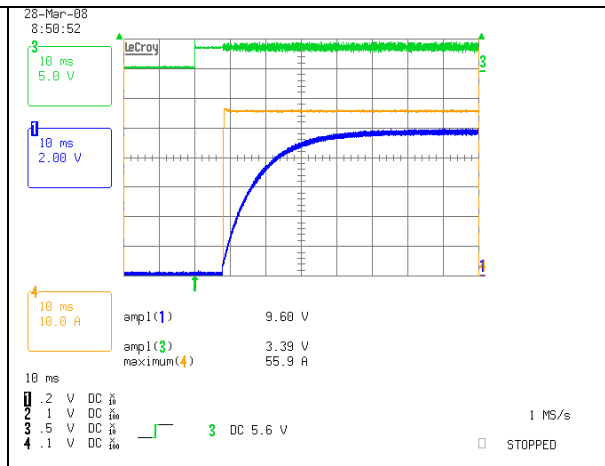

Start-up Characteristics from ON/OFF switch at nominal input and full load. Ch.1: Vo Ch.3: ON/OFF Ch.4: Io

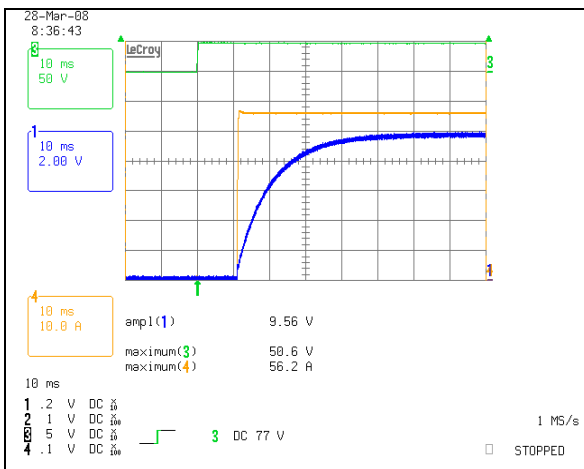

Start-up Characteristics from input voltage application at full load. Ch.1: Vo Ch.3: Vin Ch.4: Io

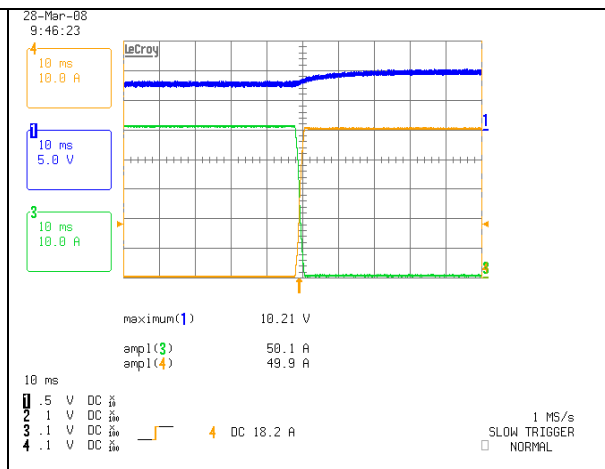

Start-up with back-biased voltage at nominal input and 50A load. Turn-on from Vin application while the load share line disconnected Ch.1: Vo Ch.3: Io2 (running) Ch. 4: Io1 (starting unit)

Electrical Characteristics (continued): iFA48055A096V- 000 through – 0x3: 9.6V, 55A Output

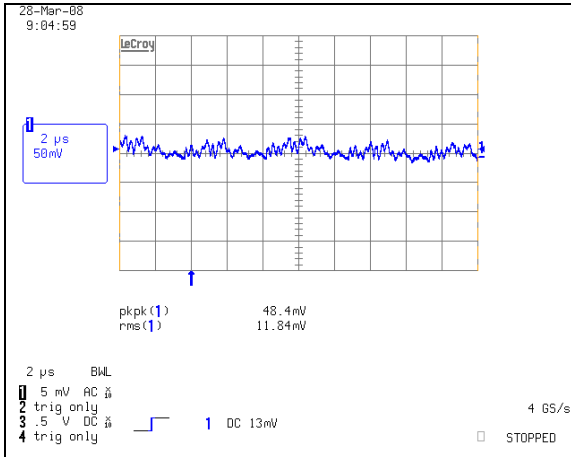

Typical Output Ripple at Nominal Input Voltage and Full Load
Ch. 1: Vo

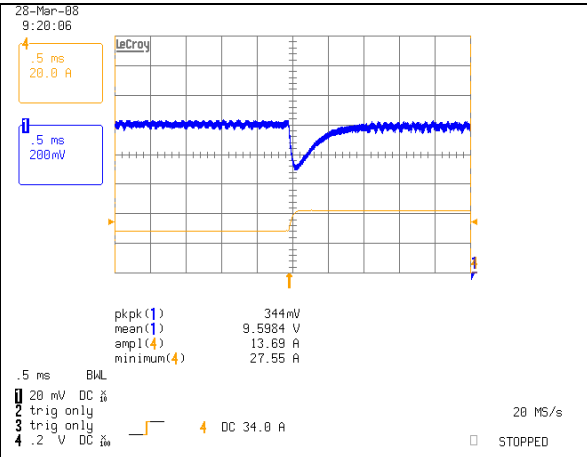

Typical Dynamic Load Response. Load step from 50% to 75% of full load, di/dt= 0.1A/μS. Vin=48V
Ch. 1: Vo Ch. 4: Io

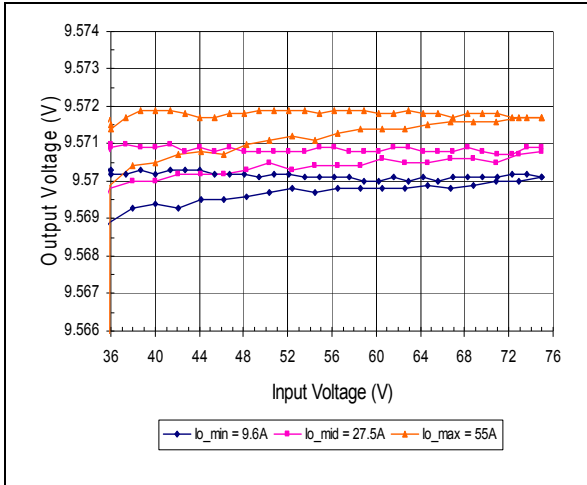

Typical Output Voltage vs. Input Voltage (Line Regulation)

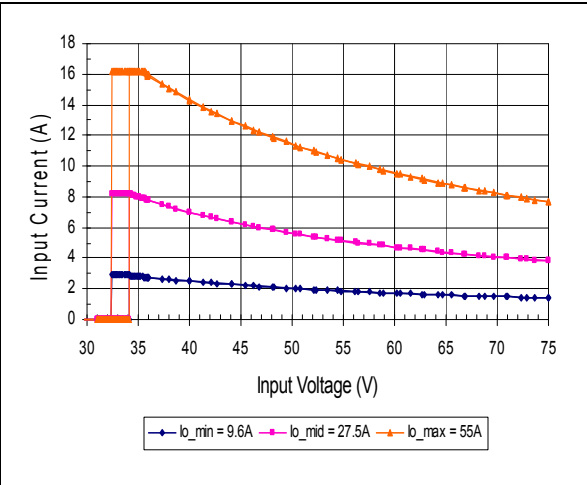

Typical Input Start-up Current vs. Load Current

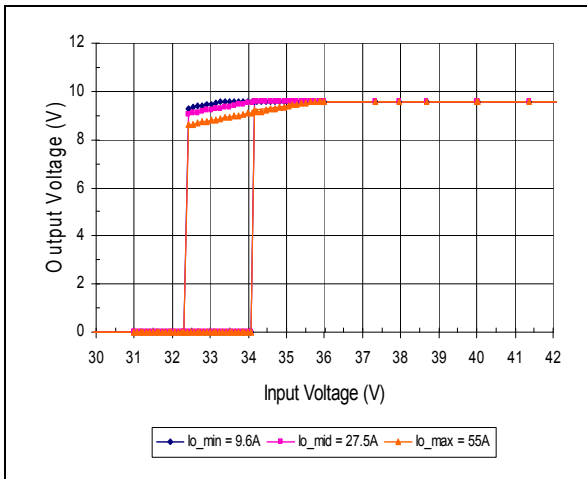

Typical Output Voltage vs. Input Voltage During Start-up

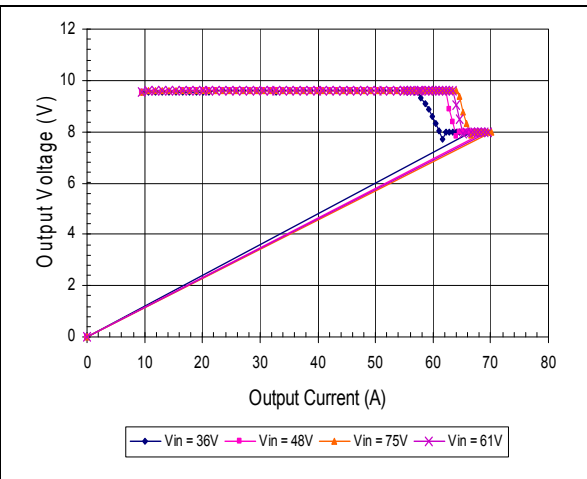

Typical Current Limit vs. Input Voltage at Ta=25 °C

Thermal Performance: iFA48055A096V- 000 through – 0x3: 9.6V, 55A Output

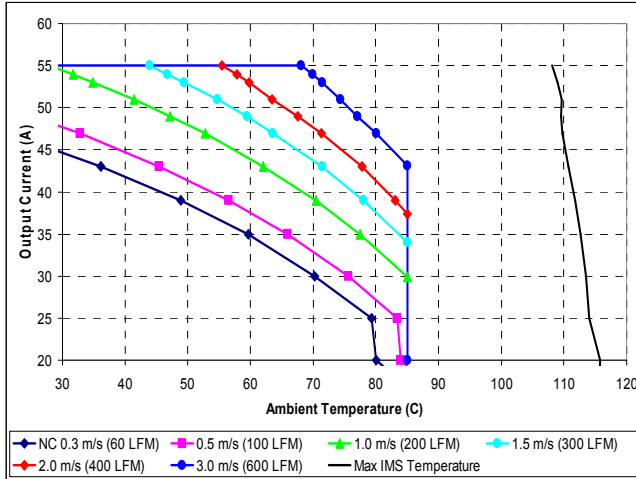

Maximum output current vs. ambient temperature at nominal input voltage for airflow rates natural convection (0.3 m/s) to 3.0 m/s with airflow from Vout(+) pins to Vout(-) pins.

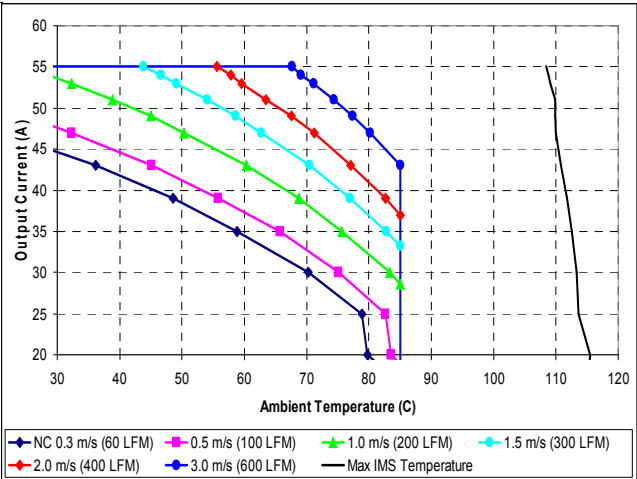

Maximum output current vs. ambient temperature at nominal input voltage for airflow rates natural convection (0.3 m/s) to 3.0 m/s with airflow from Vout(-) pins to Vout(+) pins.

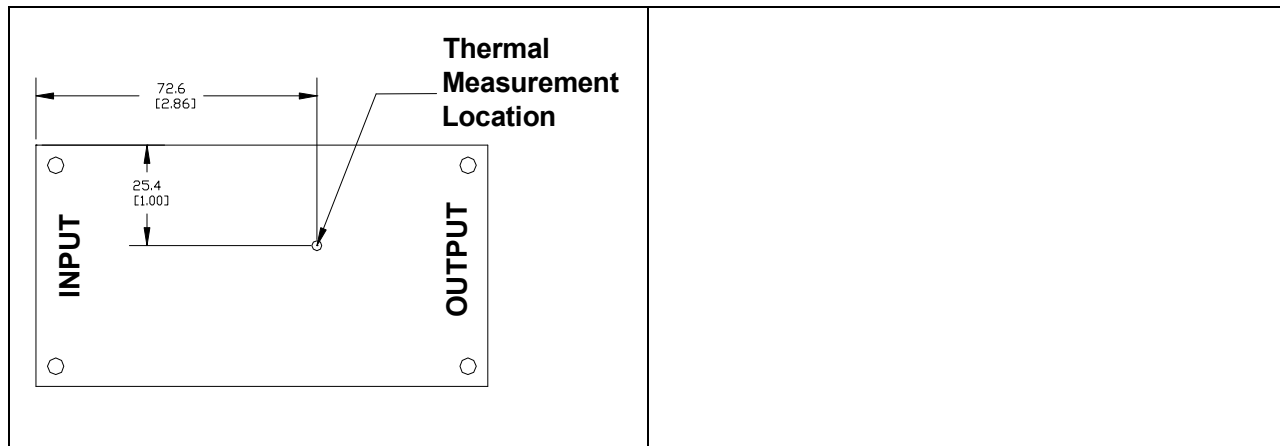

Thermal measurement location – top view

The thermal curves provided are based upon measurements made in TDK Innoveta's experimental test setup that is described in the Thermal Management section. Due to the large number of variables in system design, TDK Innoveta recommends that the user verify the module's thermal performance in the end application. The critical component should be thermo-coupled and monitored, and should not exceed the temperature limit specified in the derating curve above. It is critical that the thermocouple be mounted in a manner that gives direct thermal contact otherwise significant measurement errors may result.

Thermal Management:

An important part of the overall system design process is thermal management; thermal design must be considered at all levels to ensure good reliability and lifetime of the final system. Superior thermal design and ability to operate in severe application environments are key elements of a robust, reliable power module.

A finite amount of heat must be dissipated from the power module to the surrounding environment. This heat is transferred by the three modes of heat transfer: convection, conduction and radiation. While all three modes of heat transfer are present in every application, convection is the dominant mode of heat transfer in most applications. However, to ensure adequate cooling and proper operation, all three modes should be considered in a final system configuration.

The open frame design of the power module provides an air path to individual components. This air path improves convection cooling to the surrounding environment, which reduces areas of heat concentration and resulting hot spots.

Test Setup: The thermal performance data of the power module is based upon measurements obtained from a wind tunnel test with the setup shown in the wind tunnel figure. This thermal test setup replicates the typical thermal environments encountered in most modern electronic systems with distributed power architectures. The electronic equipment in networking, telecom, wireless, and advanced computer systems operates in similar environments and utilizes vertically mounted printed circuit boards (PCBs) or circuit cards in cabinet racks.

The power module is mounted on a 0.087 inch thick, 12-layer, 2oz/layer PCB and is vertically oriented within the wind tunnel. Power is routed on the internal layers of the PCB. The outer copper layers are thermally decoupled from the converter to better simulate the customer's application. This also results in a more conservative derating.

The cross section of the airflow passage is rectangular with the spacing between the top of the module and a parallel facing PCB kept at a constant (0.5 in). The power module's orientation with respect to the airflow direction can have a significant impact on the unit's thermal performance.

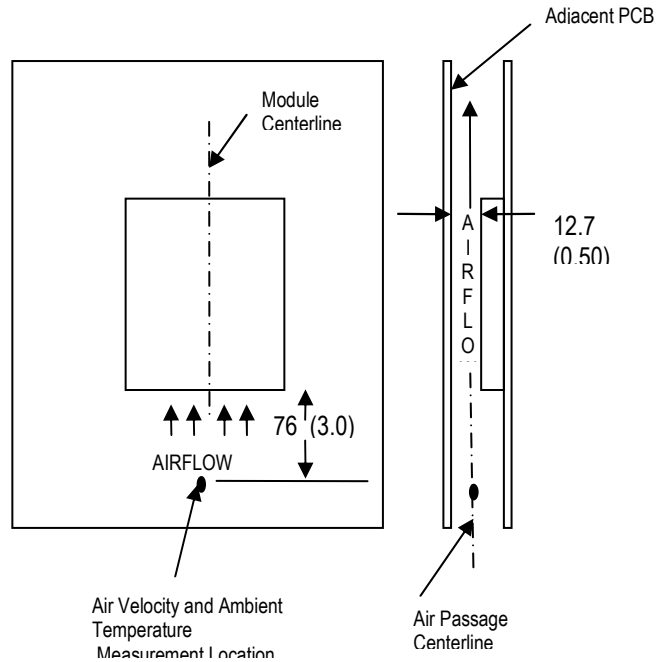

Wind Tunnel Test Setup Figure
Dimensions are in millimeters and (inches).

Thermal Derating: For proper application of the power module in a given thermal environment, output current derating curves are provided as a design guideline in the Thermal Performance section for the power module of interest. The module temperature should be measured in the final system configuration to ensure proper thermal management of the power module. For thermal performance verification, the module temperature should be measured at the location indicated in the thermal measurement location figure in the Thermal Performance section for the power module of interest. In all conditions, the power module should be operated below the maximum operating temperature shown on

the derating curve. For improved design margins and enhanced system reliability, the power module may be operated at temperatures below the maximum rated operating temperature.

Heat transfer by convection can be enhanced by increasing the airflow rate that the power module experiences. The maximum output current of the power module is a function of ambient temperature (T_{AMB}) and airflow rate as shown in the thermal performance figures on the thermal performance page for the power module of interest. The curves in the figures are shown for natural convection through 3 m/s (600 ft/min). The data for the natural convection condition has been collected at 0.3 m/s (60 ft/min) of airflow, which is the typical airflow generated by other heat dissipating components in many of the systems that these types of modules are used in. In the final system configurations, the airflow rate for the natural convection condition can vary due to temperature gradients from other heat dissipating components.

Heatsink Usage: For applications with demanding environmental requirements, such as higher ambient temperatures or higher power dissipation, the thermal performance of the power module can be improved by attaching a heatsink or cold plate. The iFA platform is designed with a base plate with four M3 X 0.5 through-threaded mounting fillings for attaching a heatsink or cold plate. The addition of a heatsink can reduce the airflow requirement, ensure consistent operation and extended reliability of the system. With improved thermal performance, more power can be delivered at a given environmental condition.

Standard heatsink kits are available from TDK Innoveta for vertical module mounting in two different orientations (longitudinal – perpendicular to the direction of the pins and transverse – parallel to the direction of the pins) as shown in the Heatsink Offering section. The heatsink kit contains four M3 x 0.5 steel mounting screws and a pre-cut thermal interface pad for improved thermal

resistance between the power module and the heatsink. The screws should be installed using a torque-limiting driver set between 0.35-0.55 Nm (3-5 in-lbs).

During heatsink assembly, the base-plate to heatsink interface must be carefully managed. A thermal pad may be required to reduce mechanical-assembly-related stresses and improve the thermal connection. Please contact TDK Innoveta Engineering for recommendation on this subject.

The system designer must use an accurate estimate or actual measure of the internal airflow rate and temperature when doing the heatsink thermal analysis. For each application, a review of the heatsink fin orientation should be completed to verify proper fin alignment with airflow direction to maximize the heatsink effectiveness. For TDK Innoveta standard heatsinks, contact TDK Innoveta Inc. for latest performance data.

Operating Information:

Output Over-Current Protection: The power modules are equipped with current limit, over-current slow hiccup, and over-current trip fast hiccup mode protection. These three protection mechanisms safeguard the module during output overload and short circuit conditions. During overload conditions, the power modules protect themselves by first entering a current limit operation mode by lowering the module output voltage. The relatively long off duration slow hiccup mode current protection circuit is triggered once the filtered peak switch current reaches the preset value. The modules will operate normally once the output current returns to the specified operating range. The fast over-current trip protection is used to protect against short circuit or switch shoot-through conditions. It is a non-latch fast acting protection circuit. The triggering threshold is normally set quite high.

Over-Current Adjustment: The over-current limit set point cannot be adjusted externally in this design.

Input Over-voltage Protection: The power modules have an internal protection circuit to help guard against application of over voltage at the input of the power module. The modules shut down to protect themselves when the input line voltage exceeds 75Vdc. When the input over-voltage condition is removed, the unit will auto restart and operate normally.

Input Under-voltage Lockout: The power modules also feature an input under voltage lockout circuitry that ensures that the power module is off at low input voltage levels. The power module will operate normally when the input voltage returns to the specified range.

Output Over-Voltage Protection: The power modules have a protection circuit, independent of the main PWM control loop that reduces the risk of over voltage appearing at the output of the power module during a fault condition. If there is a fault in the main regulation loop, the over voltage

protection circuitry will latch the power module off once it detects the over-voltage condition as specified on the electrical data page. To remove the module from the latched condition, either turn the input power off and back on or reset the remote ON/OFF pins providing that over-voltage conditions have been removed. The reset time of the ON/OFF pins should be 500ms or longer.

Output Over-Voltage Adjustment: The output over-voltage set point cannot be adjusted externally in this design.

Output Under-Voltage Warning: The iFA series power module has internal circuitry to protect against output under-voltage conditions.

Thermal Protection: When the power module exceeds the maximum operating temperature, it will turn-off to protect itself against thermal damage. The module will auto restart as soon as it cools down below the recovery temperature.

Thermal Warning: There is no thermal warning feature for this design.

Remote On/Off: The iFA series power modules have two remote on/off pins, which are isolated from the input side as well as the output side. To control the power module from the input side, the user must supply a switch between the Vin(-) terminal and the – ON/OFF terminal of ON/OFF pins. A 30KΩ external resistor with 0.5W power rating is recommended to connect between the Vin(+) terminal and the +ON/OFF terminal. The maximum allowable leakage current of the switch is 50uA. The maximum current sinking capability of the ON/OFF terminal is 5mA or less. The current required to maintain the module ON status must be greater than 1mA.

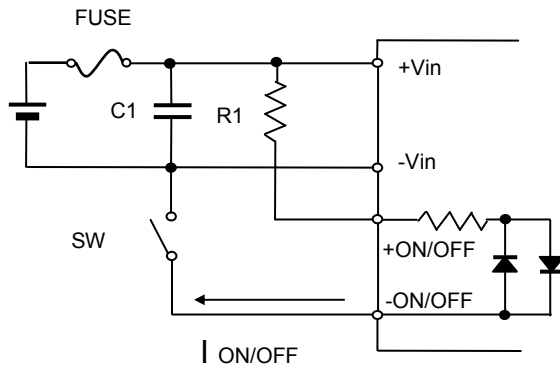

ON/OFF Control from Input Side

An alternative way to control ON/OFF is from the output side by utilizing AUX output pin (only when it is available). To do so, the user must supply a switch between the module sense(-) terminal and the -ON/OFF terminal of ON/OFF pins. A 2.5 KΩ, 0.1W resistor is recommended to connect between the module AUX pin and the +ON/OFF terminal. The maximum current sinking capability of the ON/OFF terminal is 5mA or less. The current required to maintain the module ON status must be greater than 1mA.

Other methods such as using an external power source and a transistor are also possible. Please consult the field application engineering department of TDK Innoveta for details.

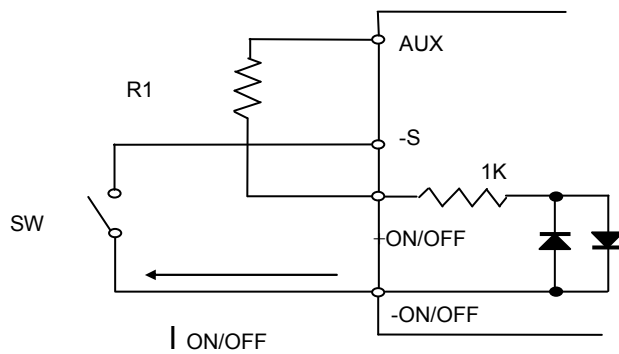

ON/OFF Control from Output Side

Output Voltage Adjustment: The output voltage of the power module is adjustable by the user using an external resistor or by applying external voltage. However, when the output voltage is increased, the input voltage range is limited as shown in the following figure.

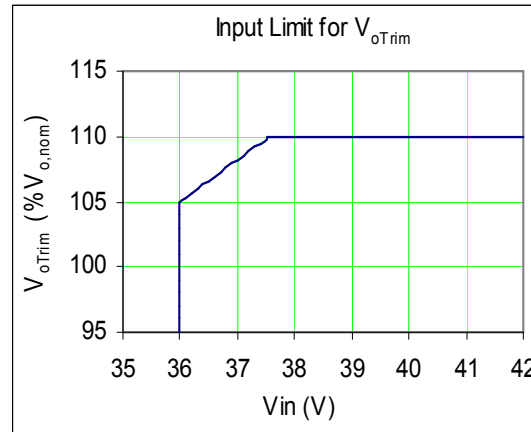

To trim the output voltage up, a fixed or variable resistor, Rext1, shall be connected between the Vout(+) pin and the sense(+) pin while the Vout(-) pin and the sense(-) pin should be shorted by a jumper wire as shown below. The trim pin should be left open. The output voltage trim-up rate is approximately 1V / KΩ. To trim the voltage up to 10.56V, a 0.96KΩ external resistor should be used.

$$R_{up} = 1003.3035 \times (V_{o_d} - 9.5756) \quad (K\Omega)$$

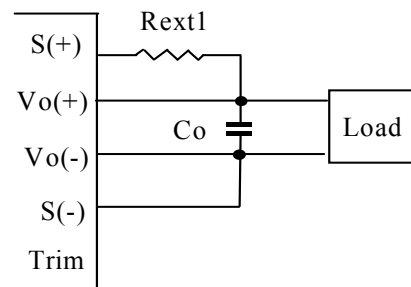

Figure Trim up Connection

If the output voltage adjustment feature is not used, the Vout(+) pin should be shorted to the sense(+) pin and the Vout(-) pin should be shorted to the sense(-) pin by jumper wires.

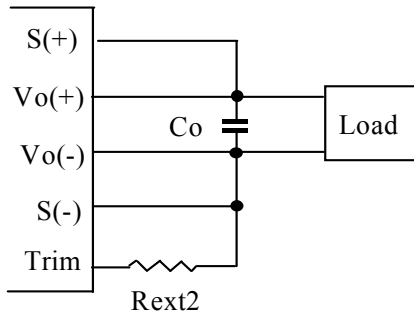
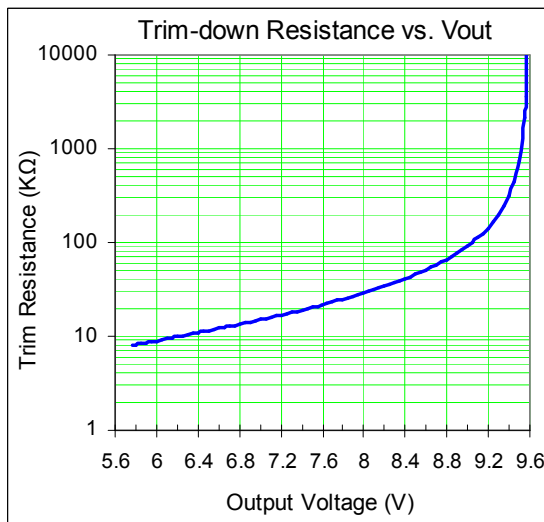

Figure Trim Down Connection

To trim the output voltage down, a fixed or variable resistor, Rext2, shall be connected between the trim pin and the sense(-) pin while the Vout(-) pin and the sense(-) pin are shorted by a jumper wire. The Vout(+) pin and the sense(+) pin should also be shorted by a jumper wire as shown below. The resistor, Rext2 can be chosen according to the following equation:

$$R_{ext2} = \left[\frac{V_{odown} - 1.31187}{1.40185 - 0.146398V_{odown}} \right]$$



In order to trim the output voltage from the minimum value (-40% down) to the maximum value (+10% up) in a linear fashion, a fixed resistor, Rext, should be connected between the trim pin and the sense(-) pin while a 11.8KΩ variable resistor, Rv, shall be connected between the Vout(+) pin and the sense(+) pin as shown below. When Rext=5.11KΩ and Rv=1.69KΩ, the output voltage trim rate is changed to approximately 0.5V / KΩ starting from 5.7V. The resistor, Rv, should be chosen according to the following equation:

$$R_v \cong 1.984 \times (V_{o_d} - 4.84833) \quad (K\Omega)$$

where Vo_d is the desired output voltage.

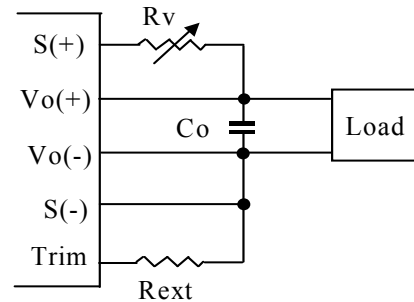
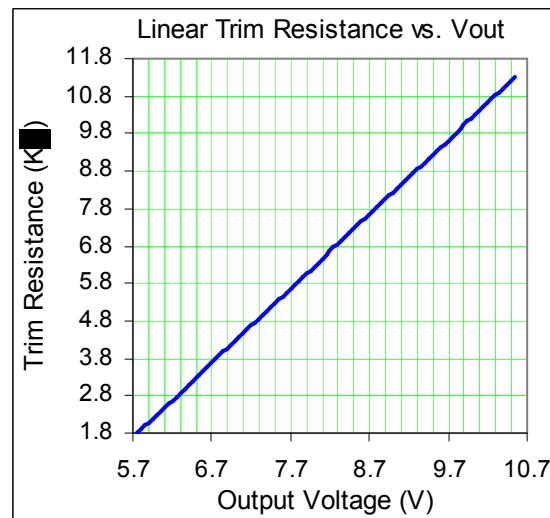

Figure Linear Trim Connection



The output voltage can also be adjusted within the same range by applying external voltage at the trim pin via a buffer. In this case, V_{o_d} can be approximately determined by the following formula:

$$V_{o_d} \cong \text{Trim Terminal Voltage} \times V_{o,nom}$$

Contact Innoveta for more details on the voltage trim using an external source.

The maximum power available from the power module is fixed. As the output voltage is trimmed up, the maximum output current must be decreased to maintain the maximum rated power of the module.

As the output voltage is trimmed, the output over-voltage set point is not adjusted. Trimming the output voltage too high may cause the output over voltage protection circuit to be triggered.

Remote Sense: The power modules feature remote sense to compensate for the effect of output distribution drops. The maximum voltage allowed between the output power terminals and output sense terminals is 0.5V. If the remote sense feature is not being used, the sense(+) terminal should be connected to the $V_{o}(+)$ terminal and the sense(-) pin should be connected to the $V_{o}(-)$ pin.

The output voltage at the $V_{o}(+)$ and $V_{o}(-)$ pins can be increased by either the remote sense or the output voltage adjustment feature. The maximum voltage increase allowed is the larger of the remote sense range or the output voltage adjustment range; it is not the sum of both.

As the output voltage increases due to the use of the remote sense, the maximum output current must be decreased for the power module to remain below the maximum rated power of the module.

Power Good: Not Applicable.

Parallel Operation: The iFA series power modules are capable of sharing the load current when multiple units are connected in parallel. The load sharing technique used is

the democratic load share scheme. By connecting the PC (or Ishare) pin of each power module with single wire, the output load current can be equally drawn from each module. All modules in parallel should be referenced to the same ground with good ground plane.

By setting the output voltage accuracy of each power module in a parallel operation to within $\pm 1\%$, the load share circuit within the module will force the load current to be shared equally among the multiple modules with $\pm 10\%$ accuracy or better from 50% to 100% of the rated load. The maximum output power rating of each module shall not be exceeded.

Auxiliary Bias Power: Not Applicable.

External Synchronization: Not Applicable.

EMC Considerations: Innoveta DC/DC converter modules are designed for use in a wide variety of systems and applications. With the help of external filters and careful layout, it is possible to meet CISPR 22 Class B. For assistance with designing for EMC compliance, please contact Innoveta technical support.

Input Impedance: The source impedance of the input power feeding the DC/DC converter module will interact with the DC/DC converter, which may cause system instability. To minimize the interaction, one or more 100 - 470 μ F input electrolytic capacitor(s) should be present if the source inductance is greater than 4 μ H.

Reliability:

The power modules are designed using Innoveta's stringent design guidelines for component derating, product qualification, and design reviews. Early failures are screened out by both burn-in and an automated final test. The MTBF is calculated to be greater than 1.50M hours at nominal input, 100% output power, 0.5" heatsink, 200LFM airflow, and $T_a = 40^\circ\text{C}$ using the Telcordia TR-332 issue 6 calculation method.

Improper handling or cleaning processes can adversely affect the appearance, testability, and reliability of the power modules. Contact Innoveta technical support for guidance regarding proper handling, cleaning, and soldering of Innoveta's power modules.

Quality:

Innoveta's product development process incorporates advanced quality planning tools such as FMEA and Cpk analysis to ensure designs are robust and reliable. All products are assembled at ISO certified assembly plants.

Input/Output Ripple and Noise Measurements:

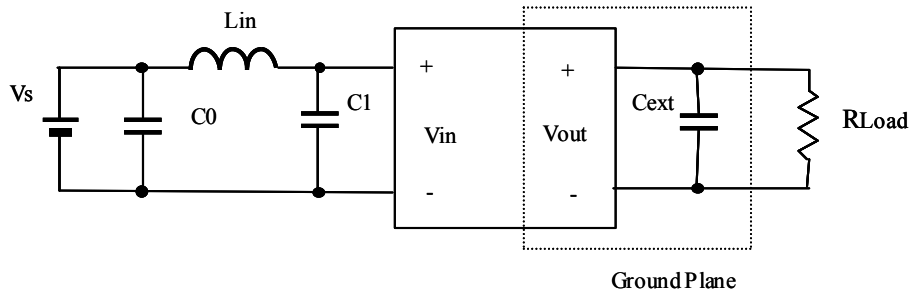

The input reflected ripple is measured with a current probe and oscilloscope. The ripple current is the current through the 15uH inductor, Lin, with $esr \leq 10 \text{ m}\Omega$, feeding a capacitor, C1, $esr \leq 700 \text{ m}\Omega @ 100\text{kHz}$, across the module input voltage pins. The capacitor C1 across the input shall be at least two (2) 470µF/100V capacitors in parallel. A 470µF/100V capacitor for C0 is also recommended.

The output voltage ripple measurement is made approximately 5 cm (2 in.) from the power module using an oscilloscope and BNC socket. The capacitor Cext consisting of a 0.1µF and a 10µF ceramic capacitors and at least two (2) 220µF or larger aluminum electrolytic or tantalum capacitor ($esr \leq 300 \text{ m}\Omega$) located about 5 cm (2 in.) from the power module. At $I_o < I_{o,min}$, the module output is not required to be within the output voltage ripple and noise specification.

Safety Considerations:

All Innoveta products are certified to regulatory standards by an independent, Certified Administrative Agency laboratory. UL 1950, 3rd edition (US & Canada), and other global certifications are typically obtained for each product platform.

The iFA products have the following certifications:

- UL 60950 (US & Canada)
- VDE 0805
- CB Scheme (IEC 950)
- CE Mark (EN60950)

For safety agency approval of the system in which the DC-DC power module is installed, the power module must be installed in compliance with the creepage and clearance requirements of the safety agency. The isolation is basic insulation. For applications requiring basic insulation, care must be taken to maintain minimum creepage and clearance distances when routing traces near the power module.

As part of the production process, the power modules are hi-pot tested from primary and secondary at a test voltage of 1500Vdc.

When the supply to the DC-DC converter is less than 60Vdc, the power module meets all of the requirements for SELV. If the input voltage is a hazardous voltage that exceeds 60Vdc, the output can be considered SELV only if the following conditions are met:

- 1) The input source is isolated from the ac mains by reinforced insulation.
- 2) The input terminal pins are not accessible.
- 3) One pole of the input and one pole of the output are grounded or both are kept floating.
- 4) Single fault testing is performed on the end system to ensure that under a single fault, hazardous voltages do not appear at the module output.

To preserve maximum flexibility, the power modules are not internally fused. An external input line normal blow fuse with a maximum value of 20A is required by safety agencies.

A lower value fuse can be selected based upon the maximum dc input current and maximum inrush energy of the power module.

Warranty:

TDK Innoveta's comprehensive line of power solutions includes efficient, high-density DC-DC converters. TDK Innoveta offers a three-year limited warranty. Complete warranty information is listed on our web site or is available upon request from TDK Innoveta.

TDK Innoveta Inc.

3320 Matrix Drive, Suite 100
Richardson, Texas 75082

Phone (877) 498-0099 Toll Free
(469) 916-4747

Fax (877) 498-0143 Toll Free
(214) 239-3101

* support@tdkinnoveta.com <http://www.tdkinnoveta.com>

*Information furnished by TDK Innoveta is believed to be accurate and reliable. However, TDK Innoveta assumes no responsibility for its use, nor for any infringement of patents or other rights of third parties, which may result from its use. No license is granted by implication or otherwise under any patent or patent rights of TDK Innoveta. TDK Innoveta components are not designed to be used in applications, such as life support systems, wherein failure or malfunction could result in injury or death. All sales are subject to TDK Innoveta's Terms and Conditions of Sale, which are available upon request. Specifications are subject to change without notice.