

## Metamere iAA Series DC/DC Power Modules 3 and 5V Inputs, 15A Output Surface Mount Power Module

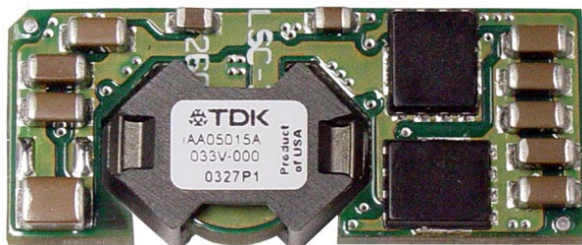

The Metamere Series offers a 50W power module in the industry's standard surface-mount footprint. The Metamere series utilizes a low component count that results in a low cost while still providing high performance. The open-frame, compact design provides flexibility by performing local voltage conversion of either a 5V or 3.3V bus. The low weight, surface mount design is well suited for almost any manufacturing environment.

### Features

- Size - 33mm x 13.5 mm x 8.5 mm (1.3 in. x 0.53 in. x 0.335 in.)
- Surface mountable
- Maximum weight 12g (0.42 oz)
- Up to 50W of output power in high ambient temperature, low airflow environments with minimal power derating
- Calculated MTBF > 14M Hours
- Positive logic on/off
- Starts with pre-biased output
- Output voltage adjustment – industry standard
- Constant switching frequency
- Remote Sense
- Full, auto-recovery protection:
  - Input under voltage
  - Short circuit
  - Thermal limit
- Applying for UL 60950 (US and Canada), VDE 0805, CB scheme (IEC950) Safety markings
- ISO Certified manufacturing facilities

### Optional Features

- Negative logic on/off



## Data Sheet: Metamere iAA Series – Non-isolated SMT Power Module

### Ordering information:

| Product Identifier | Package Size     | Platform                   | Input Voltage   | Output Current/Power | Output Units | Main Output Voltage | # of Outputs | Safety Class | Feature Set   |
|--------------------|------------------|----------------------------|-----------------|----------------------|--------------|---------------------|--------------|--------------|---------------|
| i                  | A                | A                          | 05              | 015                  | A            | 033                 | V            | -            | 00            |
| TDK Innoveta       | A – 33mmx13.5 mm | A – Metamere surface mount | 05 – 3V to 5.5V | 015 – 15A            | A – Amps     | 033 – 3.3V          | V– Single    |              | 00 – Standard |
|                    |                  |                            |                 |                      |              | 025 – 2.5V          |              |              |               |
|                    |                  |                            |                 |                      |              | 008 – 0.75V – 3.63V |              |              |               |

### Option Table:

| Feature Set | Positive Logic On/Off | Negative Logic On/Off |
|-------------|-----------------------|-----------------------|
| 00          | X                     |                       |
| 01          |                       | X                     |

### Product Offering:

| Code          | Input Voltage | Output Voltage | Output Current | Maximum Output Power | Efficiency |
|---------------|---------------|----------------|----------------|----------------------|------------|
| iAA05015A033V | 4.5-5.5       | 3.3V           | 15A            | 49.5W                | 95%        |
| iAA05015A025V | 3.0-5.5       | 2.5V           | 15A            | 37.5W                | 93%        |
| iAA05015A008V | 3.0-5.5       | 0.75V-3.63V    | 15A            | 49.5W                | 94.5%      |



3320 Matrix Drive Suite 100  
Richardson, Texas 75082

Phone (877) 498-0099 Toll Free  
(469) 916-4747

Fax (877) 498-0143 Toll Free  
(214) 239-3101

[support@tdkinnoveta.com](mailto:support@tdkinnoveta.com)  
<http://www.tdkinnoveta.com/>

## Mechanical Specification:

Dimensions are in mm [in]. Unless otherwise specified tolerances are:  $x.x \pm 0.5$  [0.02],  $x.xx \pm 0.25$  [0.010].

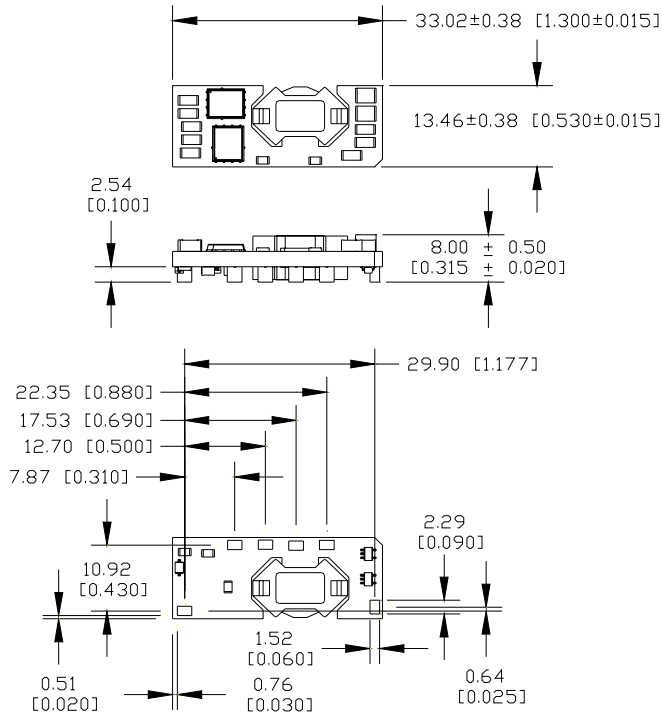

## Recommended Footprint: (top view)

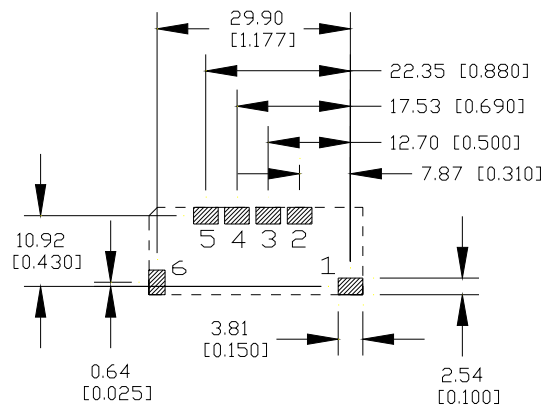

## Pin Assignment:

| PIN | FUNCTION | PIN | FUNCTION |
|-----|----------|-----|----------|
| 1   | Vin      | 4   | Trim     |
| 2   | Gnd      | 5   | Sense    |
| 3   | Vout     | 6   | On/Off   |

Pin base material is copper with tin over nickel plating.

## Data Sheet: Metamere iAA Series – Non-isolated SMT Power Module

### Absolute Maximum Ratings:

Stress in excess of Absolute Maximum Ratings may cause permanent damage to the device.

| Characteristic                   | Min   | Max  | Unit | Notes & Conditions   |
|----------------------------------|-------|------|------|--|
| Continuous Input Voltage         | -0.25 | 5.7  | Vdc  |  |
| Transient Input Voltage          | ---   | 6    | Vdc  | 10mS max.  |
| Storage Temperature              | -55   | 125  | °C   |  |
| Operating Temperature Range (Tc) | -40   | 125* | °C   | Measured at the location specified in the thermal measurement figure; maximum temperature varies with output current – see curve in the thermal performance section of the data sheet. |

\* Engineering estimate

### Input Characteristics:

Unless otherwise specified, specifications apply over all rated Input Voltage, Resistive Load, and Temperature conditions.

| Characteristic                                       | Min | Typ | Max | Unit | Notes & Conditions                                      |
|--|-----|-----|-----|------|---|
| Operating Input Voltage (2.5V and lower outputs)     | 3.0 | --- | 5.5 | Vdc  |   |
| Operating Input Voltage (3.0V and higher outputs)    | 4.5 | --- | 5.5 | Vdc  |   |
| Maximum Input Current                                | --- | --- | 16* | A    | Vin = 3 to Vin,max                                      |
| Startup Delay Time from application of input voltage | --- | 4   | --- | mS   | Vo = 0 to 0.1*Vo,nom; on/off = on, Io=Io,max, Tc=25°C   |
| Startup Delay Time from on/off                       | --- | 3   | --- | mS   | Vo = 0 to 0.1*Vo,nom; Vin = Vi,nom, Io=Io,max, Tc=25°C  |
| Output Voltage Rise Time                             | --- | 10  | --- | mS   | Io=Io,max, Tc=25°C, Vo=0.1 to 0.9*Vo,nom                |
| Input Reflected Ripple                               | --- | 5*  | --- | mApp | See input/output ripple measurement figure; BW = 20 MHz |
| Input Ripple Rejection                               | --- | 30* | --- | dB   | @ 120 Hz  |

\*Engineering Estimate

Caution: The power modules are not internally fused. An external input line normal blow fuse with a maximum value of 30A is required, see the Safety Considerations section of the data sheet.

## Data Sheet: Metamere iAA Series – Non-isolated SMT Power Module

### Electrical Data:

iAA05015A033V-000 through -001: 3.3V, 15A Output

| Characteristic                     | Min  | Typ   | Max    | Unit    | Notes & Conditions   |
|------------------------------------|------|-------|--------|---------|--|
| Output Voltage Initial Setpoint    | 3.23 | 3.3   | 3.37   | Vdc     | Vin=Vin,nom; Io=Io,max; Tc = 25°C  |
| Output Voltage Tolerance           | 3.19 | 3.3   | 3.41   | Vdc     | Over all rated input voltage, load, and temperature conditions to end of life  |
| Efficiency                         | ---  | 95    | ---    | %       | Vin=Vin,nom; Io=Io,max; Tc = 25°C  |
| Line Regulation                    | ---  | 2     | 5*     | mV      | Vin=Vin,min to Vin,max   |
| Load Regulation                    | ---  | 3     | 10*    | mV      | Io=Io,min to Io,max  |
| Temperature Regulation             | ---  | 15    | 60*    | mV      | Tc=Tc,min to Tc,max  |
| Output Current                     | 0    | ---   | 15     | A       |  |
| Output Current Limiting Threshold  | ---  | 35    | ---    | A       | Vo = 0.9*Vo,nom, Tc<Tc,max)  |
| Short Circuit Current              | ---  | 5     | ---    | A       | Vo = 0.25V, Tc = 25  |
| Output Ripple and Noise Voltage    | ---  | 42    | 75*    | mVpp    | Measured across one 0.1 uF ceramic capacitor and one 47uF ceramic capacitor – see input/output ripple measurement figure; BW = 20MHz |
|                                    | ---  | 6     | ---    | mVrms   |  |
| Output Voltage Adjustment Range    | 90   | ---   | 110    | %Vo,nom |  |
| Output Voltage Sense Range         | ---  | ---   | 10     | %Vo,nom |  |
| Dynamic Response:<br>Recovery Time | ---  | 15    | ---    | uS      | di/dt =2.5A/uS, Vin=Vin,nom; load step from 50% to 100% of Io,max  |
| Transient Voltage                  | ---  | 185   | ---    | mV      |  |
| Switching Frequency                | ---  | 300   | ---    | kHz     | Fixed  |
| External Load Capacitance          | 0    | ---   | 5000*& | uF      |  |
| Vref                               |      | 0.7   |        | V       | Required for trim calculation  |
| F                                  |      | 30100 |        | Ω       | Required for trim calculation  |
| G                                  |      | 51100 |        | Ω       | Required for trim calculation  |

\*Engineering Estimate

& Contact Innoveta for applications that require additional capacitance or very low esr

## Electrical Characteristics:

iAA05015A033V-000 through -001: 3.3V, 15A Output

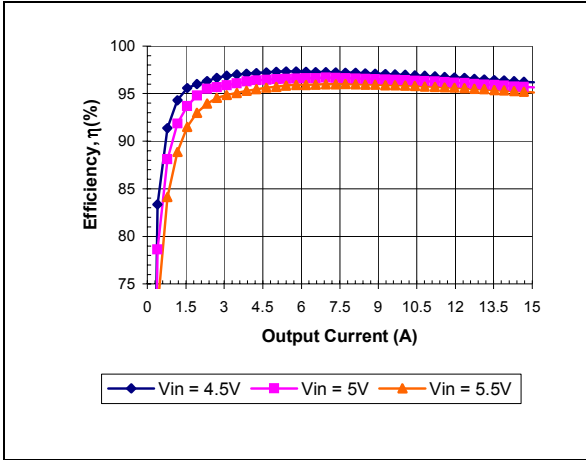

iAA05015A033V-001 Typical Efficiency vs. Input Voltage at Ta=25 degrees.

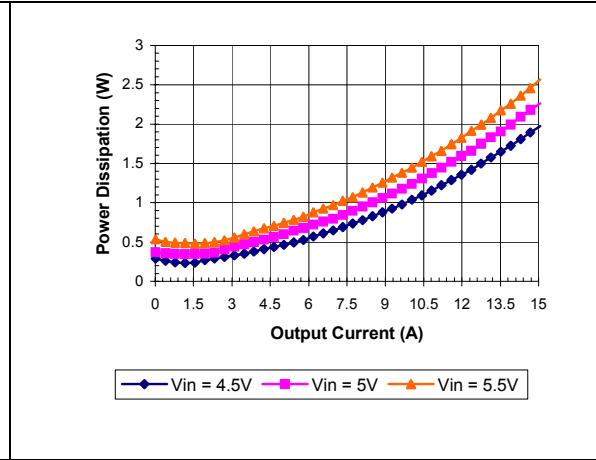

iAA05015A033V-001 Typical Power Dissipation vs. Input Voltage at Ta=25 degrees

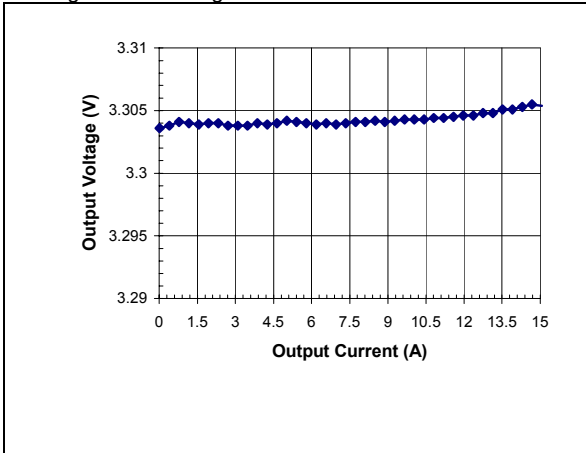

iAA048015A033V-001 Typical Output Voltage vs. Load Current at Ta = 25 degrees

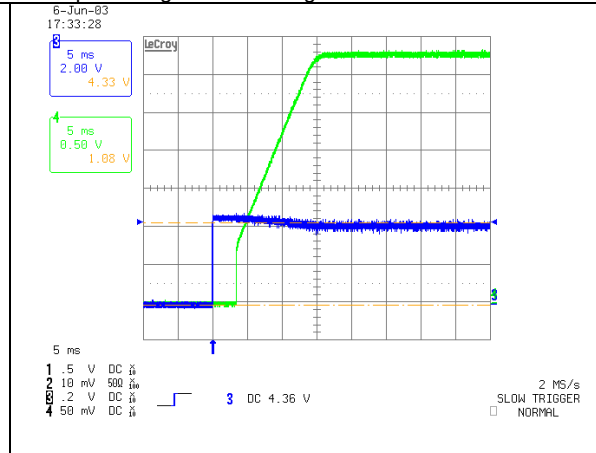

iAA05015A033V-000 Typical startup characteristic from on/off at full load. Upper trace - output voltage, lower trace – on/off signal

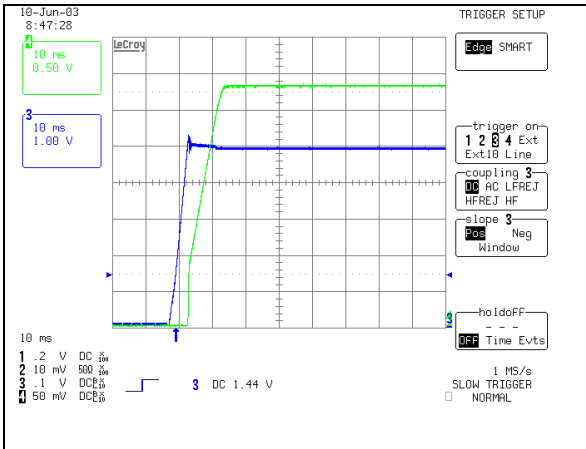

iAA05015A033V-001 Typical startup characteristic from input voltage application at full load. Upper trace - output voltage, lower trace – input voltage

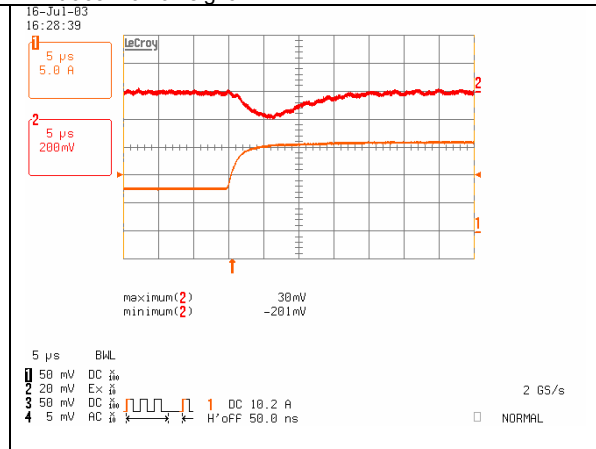

iAA05015A033V-000 Typical output voltage transient response to load step from 50% to 100% of full load with output current slew rate of 2.5A/uS.

**Electrical Characteristics (continued):**  
**iAA05015A033V-000 through -001: 3.3V, 15A Output**

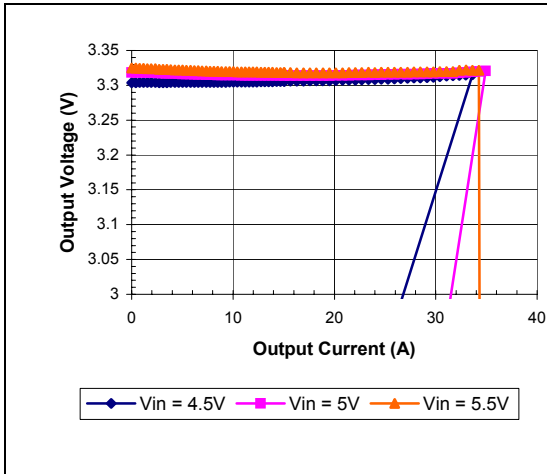

iAA05015A033V-001 Typical Output Current Limit Characteristics vs. Input Voltage at  $T_a=25$  degrees.

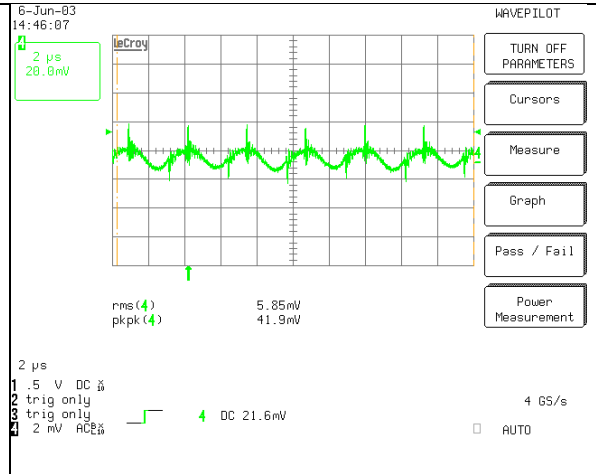

iAA05015A033V-001 Typical Output Ripple at nominal Input voltage and full load at  $T_a=25$  degrees

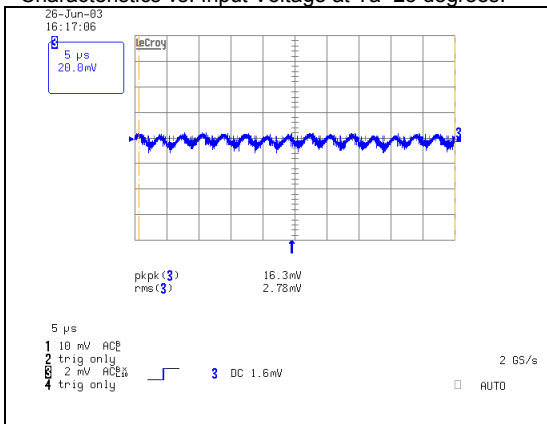

iAA05015A033V-001 Typical Input Ripple at nominal input voltage and full load at  $T_a=25$  degrees. Input capacitors - 2x150uF aluminum and 2x47uF ceramic

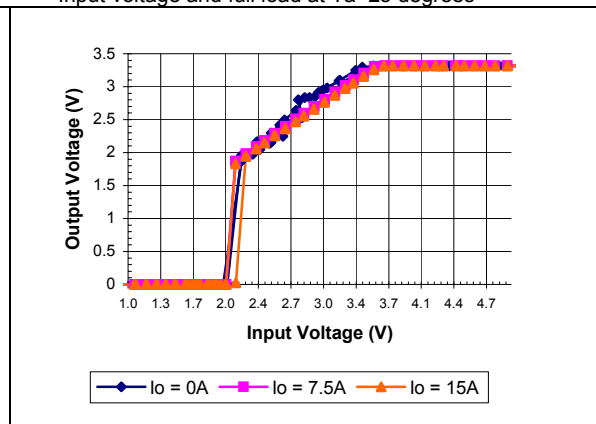

iAA05015A033V-001 Typical Output Voltage vs. Input Voltage Characteristics

| % Change of $V_{out}$ | Trim Down Resistor (Kohm) | % Change of $V_{out}$ | Trim Up Resistor (Kohm) |
|-----------------------|---------------------------|-----------------------|-------------------------|
| -5%                   | 393K                      | +5%                   | 76.6K                   |
| -10%                  | 156K                      | +10%                  | 12.7K                   |

e.g. trim down 5%

$$R_{down} := \left[ \frac{(3.135 - 0.7)}{(3.3 - 3.135)} \cdot 30100 - 51100 \right]$$

iAA05015A033V-001 Calculated resistor values for output voltage adjustment

**Thermal Performance:**

iAA05015A033V-000 through -001: 3.3V, 15A Output

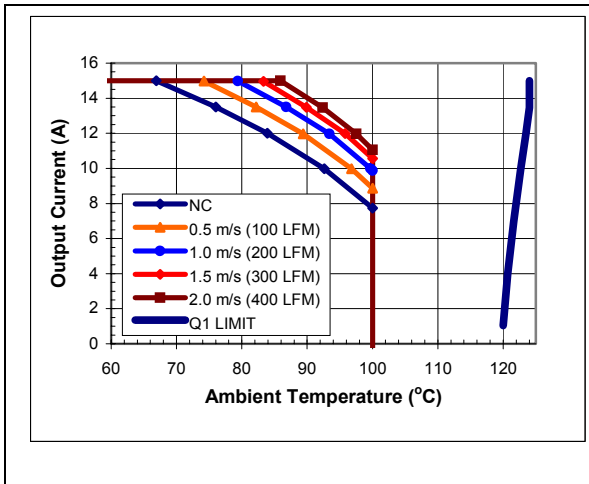

iAA05015A033V-001 maximum output current vs. ambient temperature at nominal input voltage for airflow rates natural convection (60lfm) to 400lfm with airflow from pin 1 towards pin 2.

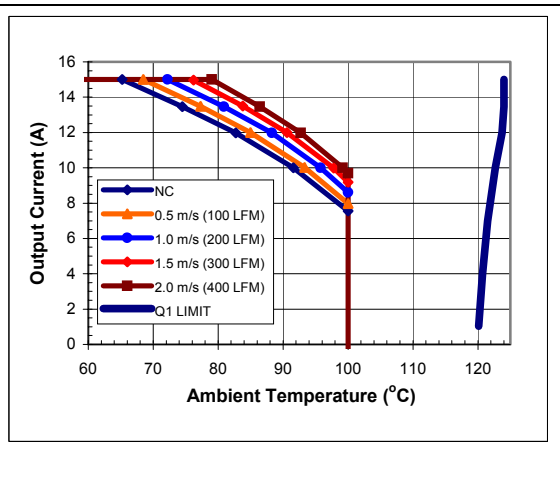

iAA05015A033V-001 maximum output current vs. ambient temperature at nominal input voltage for airflow rates natural convection (60lfm) to 400lfm with airflow from pin 6 towards pin 1

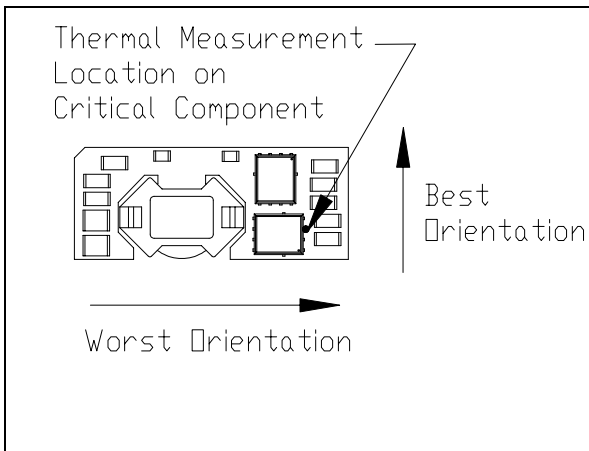

iAA05015A033V-001 thermal measurement location and airflow orientation – top view

The thermal curves provided are based upon measurements made in Innoveta's experimental test setup that is described in the Thermal Management section. Due to the large number of variables in system design, Innoveta recommends that the user verify the module's thermal performance in the end application. The critical component should be thermo coupled and monitored, and should not exceed the temperature limit specified in the derating curve above. It is critical that the thermocouple be mounted in a manner that gives direct thermal contact or significant measurement errors may result. Innoveta can provide modules with a thermocouple pre-mounted to the critical component for system verification tests.

## Data Sheet: Metamere iAA Series – Non-isolated SMT Power Module

### Electrical Data:

iAA05015A008V-000 through -001: 0.75V– 3.63V, 15A Output

| Characteristic                     |          | Min   | Typ   | Max    | Unit  | Notes & Conditions   |
|------------------------------------|----------|-------|-------|--------|-------|--|
| Output Voltage Initial Setpoint    |          | 0.738 | 0.75  | 0.762  | Vdc   | Vin=Vin,nom; Io=Io,min; Tc = 25°C  |
| Output Voltage Tolerance           |          | 0.725 | 0.75  | 0.775  | Vdc   | Over all rated input voltage, load, and temperature conditions to end of life  |
| Efficiency                         | Vo=0.75V | ---   | 82    | ---    | %     | Vin=3.3V; Io=Io,max; Tc = 25°C<br>Vin=3.3V; Io=Io,max; Tc = 25°C<br>Vin=3.3V; Io=Io,max; Tc = 25°C<br>Vin=3.3V; Io=Io,max; Tc = 25°C<br>Vin=3.3V; Io=Io,max; Tc = 25°C<br>Vin= 5V ; Io=Io,max; Tc = 25°C |
|                                    | Vo=1.2V  | ---   | 89    | ---    | %     |  |
|                                    | Vo=1.5V  | ---   | 90    | ---    | %     |  |
|                                    | Vo=1.8V  | ---   | 91    | ---    | %     |  |
|                                    | Vo=2.5V  | ---   | 94.5  | ---    | %     |  |
|                                    | Vo=3.3V  | ---   | 94.5  | ---    | %     |  |
| Line Regulation                    |          | ---   | 2     | 5*     | mV    | Vin=Vin,min to Vin,max   |
| Load Regulation                    |          | ---   | 3     | 10*    | mV    | Io=Io,min to Io,max  |
| Temperature Regulation             |          | ---   | 15    | 50*    | mV    | Tc=Tc,min to Tc,max  |
| Output Current                     |          | 0.02  | ---   | 15     | A     |  |
| Output Current Limiting Threshold  |          | ---   | 35    | ---    | A     | Vo = 0.9*Vo,nom, Tc<Tc,max)  |
| Short Circuit Current              |          | ---   | 7     | ---    | A     | Vo = 0.25V, Tc = 25  |
| Output Ripple and Noise Voltage    |          | ---   | 33    | 75*    | mVpp  | Measured across one 0.1 uF ceramic capacitor and one 47uF ceramic capacitor – see input/output ripple measurement figure; BW = 20MHz   |
|                                    |          | ---   | 5     | ---    | mVrms |  |
| Output Voltage Adjustment Range    |          | 0.75  | ---   | 3.63   | Vdc   |  |
| Output Voltage Sense Range         |          | ---   | ---   | 0.5    | V     |  |
| Dynamic Response:<br>Recovery Time |          | ---   | 15    | ---    | uS    | di/dt =2.5A/uS, Vin=Vin,nom; load step from 50% to 100% of Io,max  |
| Transient Voltage                  |          | ---   | 185   | ---    | mV    |  |
| Switching Frequency                |          | ---   | 300   | ---    | kHz   | Fixed  |
| External Load Capacitance          |          | 0     | ---   | 5000*& | uF    |  |
| Vref                               |          |       | 0.7   |        | V     | Required for trim calculation  |
| F                                  |          |       | 30100 |        | Ω     | Required for trim calculation  |
| G                                  |          |       | 5110  |        | Ω     | Required for trim calculation  |

\*Engineering Estimate

& Contact Innoveta for applications that require additional capacitance or very low esr

# Data Sheet: Metamere iAA Series – Non-isolated SMT Power Module

## Electrical Characteristics:

iAA05015A008V-000 through -001: 0.75V – 3.63V, 15A Output

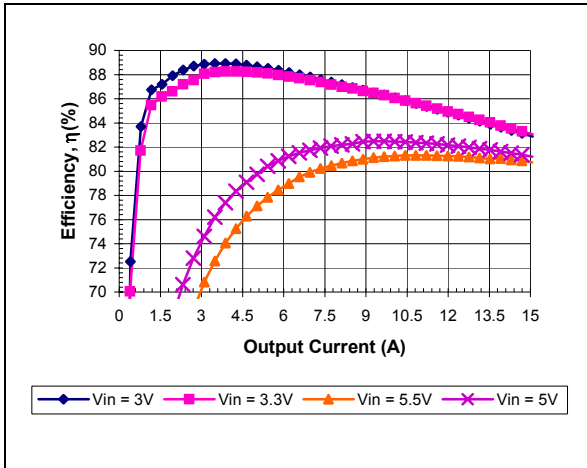

iAA05015A008V-001 Typical Efficiency vs. Input Voltage at Ta=25 degrees with Vout=0.75V

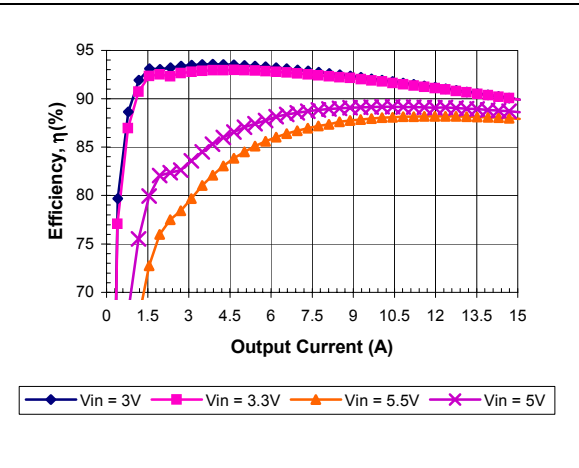

iAA05015A008V-001 Typical Efficiency vs. Input Voltage at Ta=25 degrees with Vout=1.5V

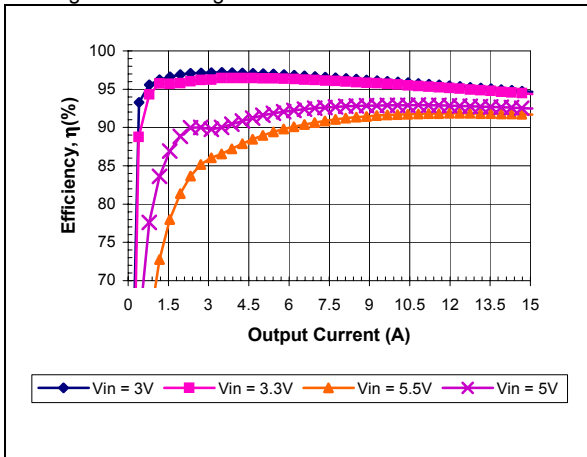

iAA05015A008V-001 Typical Efficiency vs. Input Voltage at Ta=25 degrees with Vout=2.5V

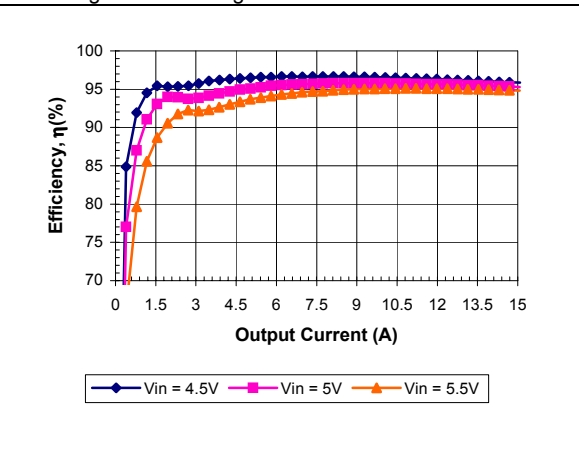

iAA05015A008V-001 Typical Efficiency vs. Input Voltage at Ta=25 degrees with Vout=3.3V

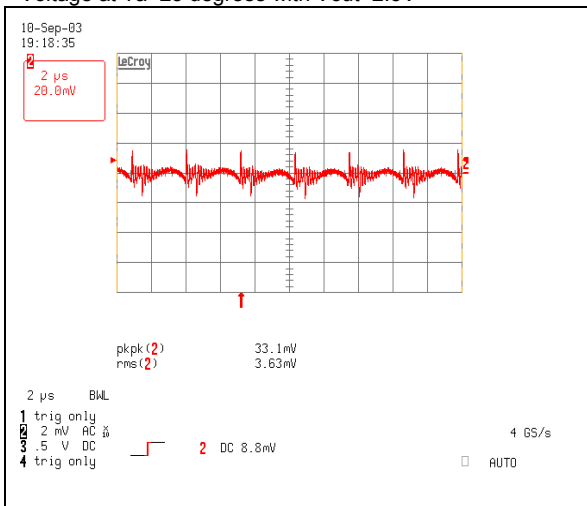

iAA05015A008V-001 Typical Output Ripple at nominal Input voltage and full load at Ta=25 degrees with Vout=0.75V

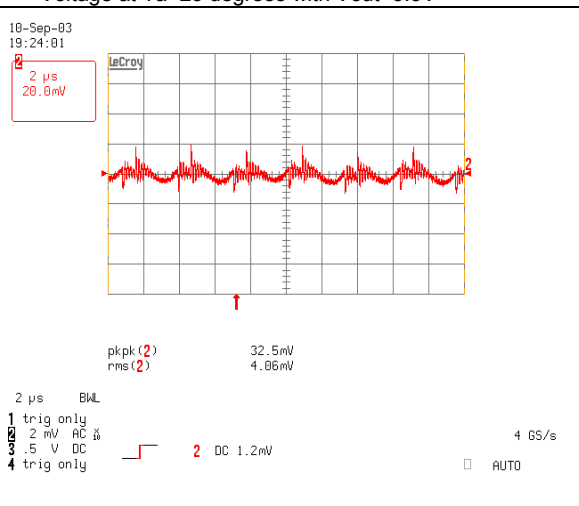

iAA05015A008V-001 Typical Output Ripple at nominal Input voltage and full load at Ta=25 degrees with Vout=3.3V

# Data Sheet: Metamere iAA Series – Non-isolated SMT Power Module

## Electrical Characteristics (continued):

iAA05015A008V-000 through -001: 0.75V – 3.63V, 15A Output

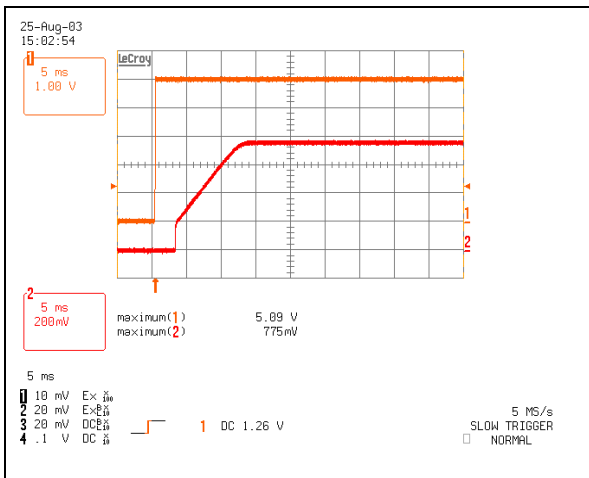

iAA05015A008V-000 Typical startup characteristic from on/off at full load. Lower trace - output voltage, upper trace – on/off signal

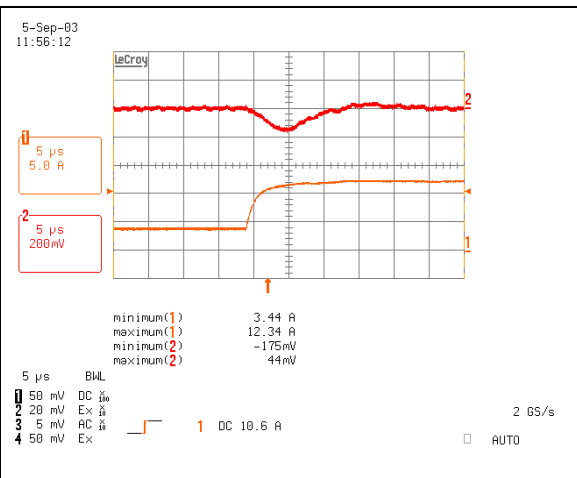

iAA05015A008V-000 Typical output voltage transient response to load step from 25% to 75% of full load with output current slew rate of 2.5A/uS (Vout=3.3V) . Lower trace - output current, upper trace – output voltage

| Vout | Trim Up Resistor (Kohm) | Vout | Trim Up Resistor (Kohm) |
|------|-------------------------|------|-------------------------|
| 0.9V | 135.36K                 | 1.8V | 14.96K                  |
| 1.2V | 41.71K                  | 2.5V | 6.93K                   |
| 1.5V | 22.98K                  | 3.3V | 3.15K                   |

e.g. trim up to 3.3V

$$R_{up} := \left[ \frac{(0.7 \cdot 30100)}{(3.3 - 0.75)} - 5110 \right]$$

iAA05015A008V-001 Calculated resistor values for output voltage adjustment

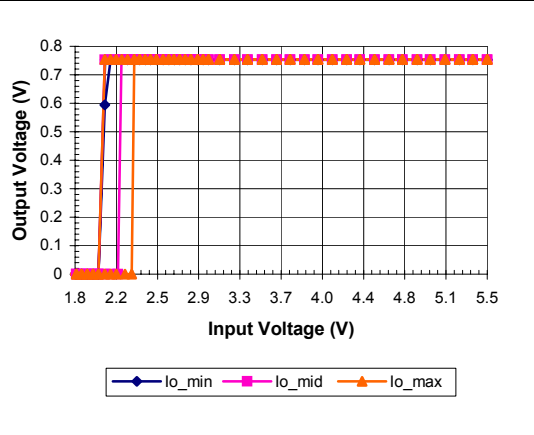

iAA05015A008V-001 Typical Output Voltage vs. Input Voltage Characteristics

**Thermal Performance:**

iAA05015A008V-000 through -001: 0.75V – 3.63V, 15A Output

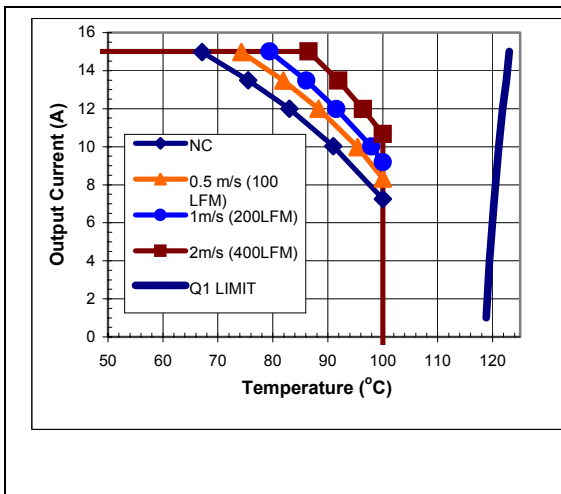

iAA05015A008V-001 maximum output current vs. ambient temperature with 5V input and 3.3V output for airflow rates natural convection (60lfm) to 400lfm with airflow from pin 1 towards pin 2.

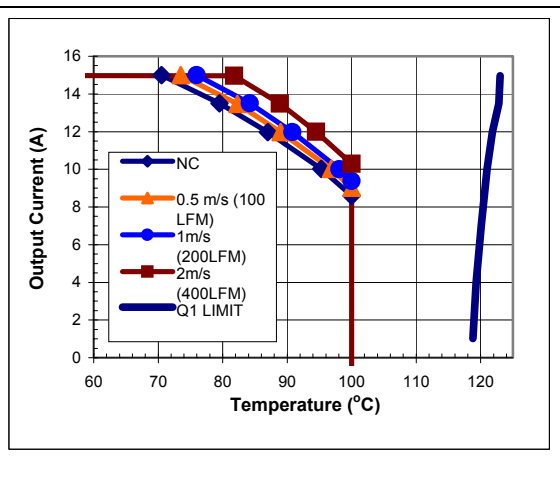

iAA05015A008V-001 maximum output current vs. ambient temperature with 3.3V input and 2.5V output for airflow rates natural convection (60lfm) to 400lfm with airflow from pin 1 towards pin 2

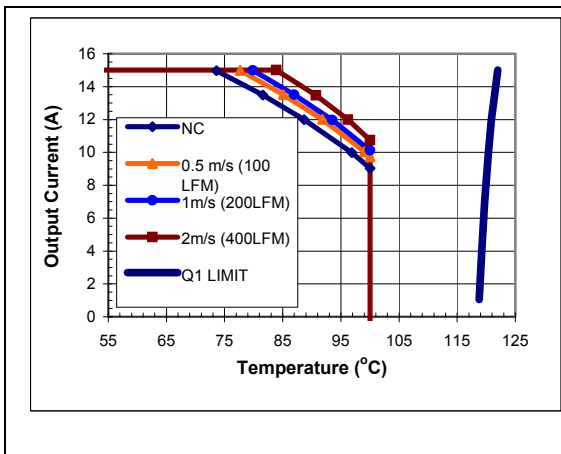

iAA05015A008V-001 maximum output current vs. ambient temperature with 3.3V input and 0.75V output for airflow rates natural convection (60lfm) to 400lfm with airflow from pin 1 towards pin 2.

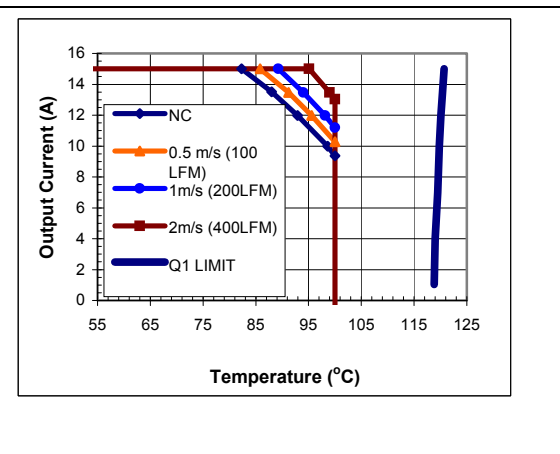

iAA05015A008V-001 maximum output current vs. ambient temperature with 5V input and 0.75V output for airflow rates natural convection (60lfm) to 400lfm with airflow from pin 1 towards pin 2

Thermal measurement location is the same as shown in the thermal measurement location figure on the iAA05015A033V thermal performance page.

**Soldering Information:**

iAA surface mountable power modules are intended to be compatible with standard surface mount component soldering processes and either hand placed or automatically picked and placed. The figure below shows the position for vacuum pick up. The maximum weight of the power module is 12g (0.42 oz.). Improper handling or cleaning processes can adversely affect the appearance, testability, and reliability of the power modules. Contact Innoveta technical support for guidance regarding proper handling, cleaning, and soldering of Innoveta's power modules.

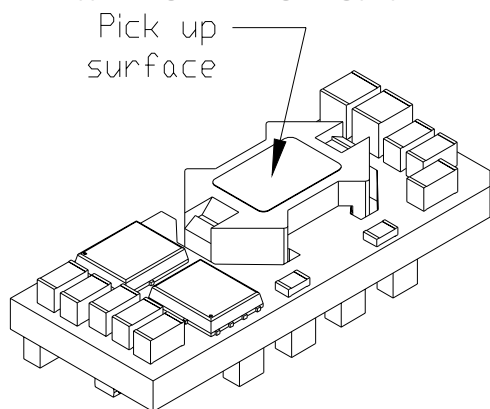

**Reflow Soldering**

The iAA platform is an open frame power module manufactured with SMT (surface mount technology). Due to the high thermal mass of the power module and sensitivity to heat of some SMT components, extra caution should be taken when reflow soldering. Failure to follow the reflow soldering guidelines described below may result in permanent damage and/or affect performance of the power modules.

The iAA power modules can be soldered using natural convection, forced convection, IR (radiant infrared), and convection/IR reflow technologies. The module should be thermally characterized in its application to develop a temperature profile. Thermal couples should be mounted to pin 2 and pin 6 and be monitored. The temperatures in the figure are maximum limits. Oven temperature and conveyer belt speeds should be controlled to ensure these limits are not exceeded. To ensure a reliable solder joint, a minimum solder paste volume of 1.25 mm<sup>3</sup> (76,500 cubic mils) is required with a minimum solder paste thickness of at least 0.13 mm (0.0051 in.). In most manufacturing processes, the required solder paste can be applied with a standard 6 mil stencil. iAA power modules are tested for lead coplanarity as part of the manufacturing process.

|   |   |
|---|---|
| <p>Drawing to be provided in next issue</p> | <p>Drawing to be provided in next issue</p> |
|---|---|

iAA Power Module maximum pin temperature profile

iAA Power Module suggested reflow-soldering profile

## Thermal Management:

An important part of the overall system design process is thermal management; thermal design must be considered at all levels to ensure good reliability and lifetime of the final system. Superior thermal design and the ability to operate in severe application environments are key elements of a robust, reliable power module.

A finite amount of heat must be dissipated from the power module to the surrounding environment. This heat is transferred by the three modes of heat transfer: convection, conduction and radiation. While all three modes of heat transfer are present in every application, convection is the dominant mode of heat transfer in most applications. However, to ensure adequate cooling and proper operation, all three modes should be considered in a final system configuration.

The open frame design of the power module provides an air path to individual components. This air path improves convection cooling to the surrounding environment, which reduces areas of heat concentration and resulting hot spots.

**Test Setup:** The thermal performance data of the power module is based upon measurements obtained from a wind tunnel test with the setup shown in the wind tunnel figure. This thermal test setup replicates the typical thermal environments encountered in most modern electronic systems with distributed power architectures. The electronic equipment in networking, telecom, wireless, and advanced computer systems operates in similar environments and utilizes vertically mounted PCBs or circuit cards in cabinet racks.

The power module, as shown in the figure, is mounted on a printed circuit board (PCB) and is vertically oriented within the wind tunnel. The cross section of the airflow passage is rectangular. The spacing between the top of the module and a parallel facing PCB is kept at a constant (0.5 in). The power module's orientation with respect to the airflow direction can have a significant impact on the module's thermal performance.

**Thermal Derating:** For proper application of the power module in a given thermal environment, output current derating curves are provided as a design guideline on the Thermal Performance section for the

power module of interest. The module temperature should be measured in the final system configuration to ensure proper thermal management of the power module. For thermal performance verification, the module temperature should be measured at the component indicated in the thermal measurement location figure on the thermal performance page for the power module of interest. In all conditions, the power module should be operated below the maximum operating temperature shown on the derating curve. For improved design margins and enhanced system reliability, the power module may be operated at temperatures below the maximum rated operating temperature.

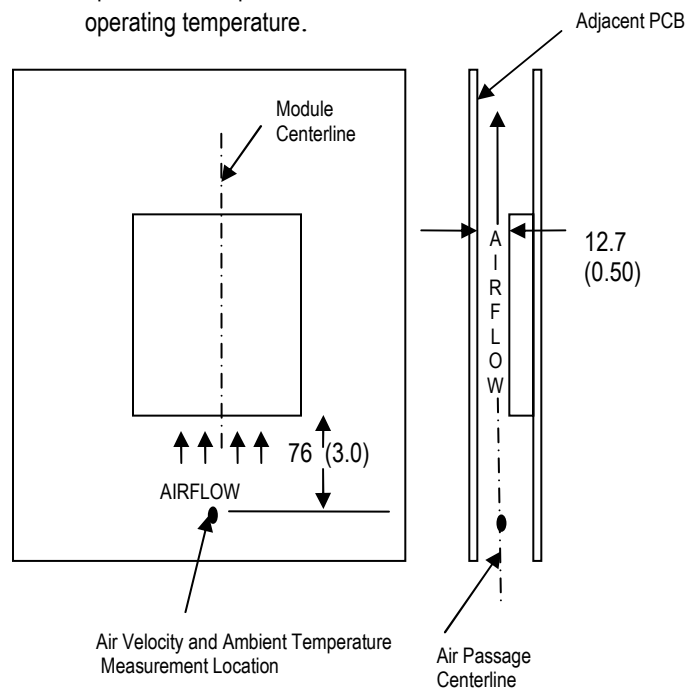

**Wind Tunnel Test Setup Figure** Dimensions are in millimeters and (inches).

Heat transfer by convection can be enhanced by increasing the airflow rate that the power module experiences. The maximum output current of the power module is a function of ambient temperature ( $T_{AMB}$ ) and airflow rate as shown in the thermal performance figures on the thermal performance page for the power module of interest. The curves in the figures are shown for natural convection through 2 m/s (400 ft/min). The data for the natural convection condition has been collected at 0.3 m/s (60 ft/min) of airflow, which is the typical airflow generated by other heat dissipating components in many of the systems that these types of modules are used in. In the final system configurations, the airflow rate for the natural convection condition can vary due to temperature gradients from other heat dissipating components.

## Operating Information:

**Over-Current Protection:** The power modules have short circuit protection to protect the module during severe overload conditions. During overload conditions, the power modules may protect themselves by entering a hiccup current limit mode or by tripping the over temperature protection. The modules will operate normally once the output current returns to the specified operating range.

**Thermal Protection:** When the power modules exceed the maximum operating temperature, the modules may turn-off to safeguard the power unit against thermal damage. The module will auto restart as the unit is cooled below the over temperature threshold.

**Remote On/Off:** - The power modules have an internal remote on/off circuit. The user must supply an open-collector or compatible switch between the Vin(-) pin and the on/off pin. The maximum voltage generated by the power module at the on/off terminal is 6.5V. The maximum allowable leakage current of the switch is 50uA. The switch must be capable of maintaining a low signal Von/off < 0.5V while sinking 1mA.

The standard on/off logic is positive logic. The power module will turn on if terminal 6 is left open and will be off if terminal 6 is connected to terminal 2. If the positive logic circuit is not being used, terminal 6 should be left open.

An optional negative logic is available. The power module will turn on if terminal 6 is connected to terminal 2, and it will be off if terminal 6 is left open. If the negative logic feature is not being used, terminal 2 should be shorted to terminal 6.

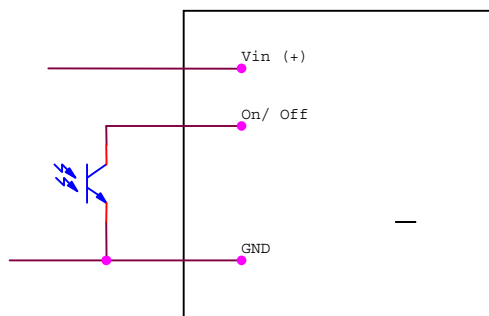

**On/Off Circuit for positive or negative logic**

**Remote Sense:** The power modules feature remote sense to compensate for the effect of output distribution drops. The output voltage sense range defines the maximum voltage allowed between the output power terminals and output sense terminals, and it is found on the electrical data page for the power module of interest. If the remote sense feature is not being used, the Sense(+) terminal should be connected to the Vo(+) terminal.

The output voltage at the Vo(+) terminal can be increased by either the remote sense or the output voltage adjustment feature. The maximum voltage increase allowed is the larger of the remote sense range or the output voltage adjustment range; it is not the sum of both.

As the output voltage increases due to the use of the remote sense, the maximum output current must be decreased for the power module to remain below its maximum power rating.

**Output Voltage Adjustment:** The output voltage of the power module may be adjusted by using an external resistor connected between the Vout trim terminal (pin 4) and either the Vo(+) or GND terminal. If the output voltage adjustment feature is not used, pin 4 should be left open. Care should be taken to avoid injecting noise into the power module's trim pin. A small 0.01uF capacitor between the power module's trim pin and GND pin may help avoid this.

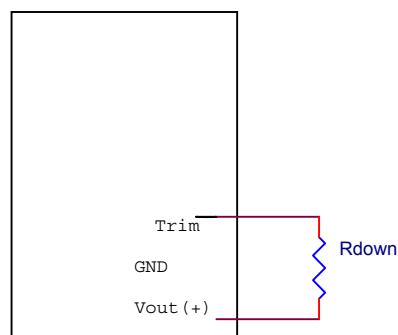

**Circuit to decrease output voltage**

With a resistor between the trim and Vo(+) terminals, the output voltage is adjusted down. To adjust the output voltage from Vo,nom to Vo,down the trim

resistor should be chosen according to the following equation:

$$R_d := \left[ \frac{(V_{odown} - V_{ref})}{(V_{onom} - V_{odown})} \cdot F - G \right]$$

The values of  $V_{ref}$ ,  $F$ , and  $G$  are found in the electrical data section for the power module of interest. The current limit set point does not increase as the module is trimmed down, so the available output power is reduced.

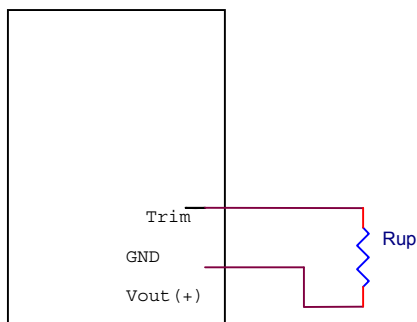

### Circuit to increase output voltage

With a resistor between the trim and GND terminals, the output voltage is adjusted up. To adjust the output voltage from  $V_{o,nom}$  to  $V_{o,up}$  the trim resistor should be chosen according to the following equation:

$$R_u := \left[ \frac{(V_{ref} \cdot F)}{(V_{oup} - V_{onom})} - G \right]$$

The values of  $V_{ref}$ ,  $F$ , and  $G$  are found in the electrical data section for the power module of interest. The maximum power available from the power module is

fixed. As the output voltage is trimmed up, the maximum output current must be decreased to maintain the maximum rated power of the module.

**EMC Considerations:** Innoveta power modules are designed for use in a wide variety of systems and applications. For assistance with designing for EMC compliance, please contact Innoveta technical support.

### Input Impedance:

The source impedance of the power feeding the DC/DC converter module will interact with the DC/DC converter. To minimize the interaction, low-esr capacitors should be located at the input to the module. Data is provided on the electrical characteristics page, showing the typical input ripple voltage with two 47uF ceramic capacitors (TDK part C3225X5R0J476M) and two 150uF aluminum capacitors (Kemet part A700X157M006AT).

### Reliability:

The power modules are designed using Innoveta's stringent design guidelines for component derating, product qualification, and design reviews. The MTBF is calculated to be greater than 14.6M hours at full output power and  $T_a = 40^\circ\text{C}$  using the Telcordia SR-332 calculation method.

### Quality:

TDK Innoveta's product development process incorporates advanced quality planning tools such as FMEA and Cpk analysis to ensure designs are robust and reliable. All products are assembled at ISO certified assembly plants.

## Input/Output Ripple and Noise Measurements:

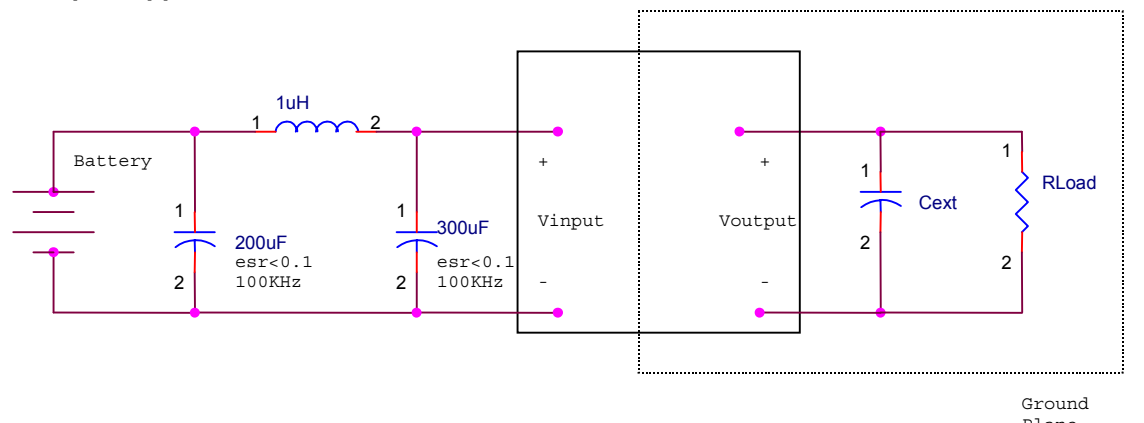

The input reflected ripple is measured with a current probe and oscilloscope. The ripple current is the current through the 1µH inductor.

The output ripple measurement is made approximately 9 cm (3.5 in.) from the power module using an oscilloscope and BNC socket. The capacitor C<sub>ext</sub> is located about 5 cm (2 in.) from the power module; its value varies from code to code and is found on the electrical data page for the power module of interest under the ripple & noise voltage specification in the Notes & Conditions column.

## Safety Considerations:

As of the publishing date, certain safety agency approvals may have been received on the iAA series and others may still be pending. Check with Innoveta for the latest status of safety approval on the iAA product line.

For safety agency approval of the system in which the DC-DC power module is installed, the power module must be installed in compliance with the creepage and clearance requirements of the safety agency.

To preserve maximum flexibility, the power modules are not internally fused. An external input line normal blow fuse with a maximum value of 30A is required by safety agencies. A lower value fuse can be selected based upon the maximum dc input current and maximum inrush energy of the power module.

## Warranty:

TDK Innoveta's comprehensive line of power solutions includes efficient, high-density DC-DC converters. TDK Innoveta offers a three-year limited warranty. Complete warranty information is listed on our web site or is available upon request from TDK Innoveta.



3320 Matrix Drive Suite 100  
Richardson, Texas 75082

Phone (877) 498-0099 Toll Free  
(469) 916-4747

Fax (877) 498-0143 Toll Free  
(214) 239-3101

[support@tdkinnoveta.com](mailto:support@tdkinnoveta.com)  
<http://www.tdkinnoveta.com/>

Information furnished by TDK Innoveta is believed to be accurate and reliable. However, TDK Innoveta assumes no responsibility for its use, nor for any infringement of patents or other rights of third parties, which may result from its use. No license is granted by implication or otherwise under any patent or patent rights of TDK Innoveta. TDK Innoveta components are not designed to be used in applications, such as life support systems, wherein failure or malfunction could result in injury or death. All sales are subject to TDK Innoveta's Terms and Conditions of Sale, which are available upon request.

Specifications are subject to change without notice.

 is a trademark or registered trademark of TDK Corporation.