

HEATSINK MOUNTING GUIDELINE FOR TDK INNOVETA POWER MODULES

The thermal performance and reliability of a power module can be improved with the use of a heatsink. TDK Innoveta Inc. (TII) offers a variety of heatsink solutions for our power modules. Proper design and installation of the heatsink is critical to the performance and reliability of the power module. Improper heatsink design and installation can cause excessive mechanical stress that can result in premature failure of the module.

Heatsink Design

TII heatsinks are designed such that they minimize the thermal resistance and mechanical strain between the heatsink and power module. It is recommended that TII power modules be coupled with TII heatsinks if operating in harsh thermal environments. If a custom heatsink/cold plate is used, it is highly recommended that they have the following features:

- **Flat contact surface:** The heatsink/cold plate mating surface should be flat with a maximum of .001 inch flatness per inch of surface. For example, the full brick heatsink measures 4.6 inch long by 2.4 inch wide. Thus the maximum allowable flatness along the length is .0046 inch and .0024 inch along the width. It is recommended that the mating surface be machined to meet this flatness requirement. Typical extruded or casted parts do not meet this requirement.
- **Thermal interface material:** Due to the flatness irregularities of both the heatsink and power module baseplate, a thermal interface material must be used between the heatsink and the power module baseplate to minimize the thermal contact resistance. A conformal thermally conductive interface material or pad is required to fill the gaps. The pad should be between 0.005 to 0.008 inch thick and have a minimum thermal conductivity of 2 W/m-K. TII heatsinks come with 0.005 inch thick Berquist QPAD3 thermal interface material. The interface material should completely surround the mounting hole/slot (see Figure 1). Pad clearance hole diameter should be 1.02 mm (0.040 inch) larger than heatsink/cold plate mounting hole. This will prevent excessive flexing of the base plate when torquing in screws. Thermal grease is not recommended for the thermal interface material.
- **Heatsink/cold plate hole size:** For non-threaded heatsink/cold plate, holes are preferred over slots. If slots are required, closed end slots are preferred. Open ended slots should not be utilized since they can result in additional strain on the power module when the heatsink is mounted. Heatsink/cold plate mounting holes should be 3.3 mm (0.130 inch) in diameter. All holes and sharp edges shall be de-burred.

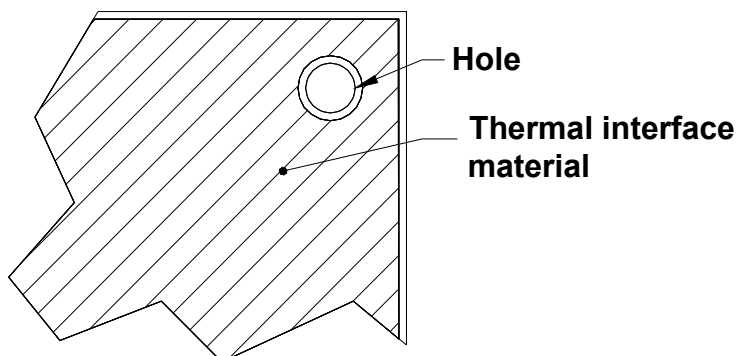

Figure 1 - Thermal Pad Design

Assembly

Some TII power modules come equipped with mounting studs for fastening module to PCB and/or heatsink/cold plate. TII mounting studs come in two varieties: threaded and non-threaded. There are certain guidelines to follow when mounting a heatsink or cold plate to the power module that will help prevent reliability issues.

- Assembly sequence: It is recommended that the module be assembled in the following order:
 - Threaded stud version (Figure 2):
 - 1) Fix power module to PCB.
 - 2) Mount heatsink/cold plate to power module.
 - 3) Solder power module to PCB.
 - Non-threaded stud version (Figure 3):
 - 1) Fix power module to PCB and heatsink/cold plate.
 - 2) Solder power module to PCB.

- PCB holes: Refer to appropriate datasheet for mounting stud footprint. Mounting holes on PCB should be 3.40mm (.134 inch) diameter plated through holes with 5.5mm (.217 inch) diameter land pad.

- Hardware (threaded studs): M3 x 0.5 screws should be used. Screws should protrude a minimum of 3.8mm (0.15 inch) into fastening stud. Locking washers should be used as shown.

- Hardware (non-threaded studs): M3 x 0.5 or smaller screws should be used. Locking washers should be used as shown.

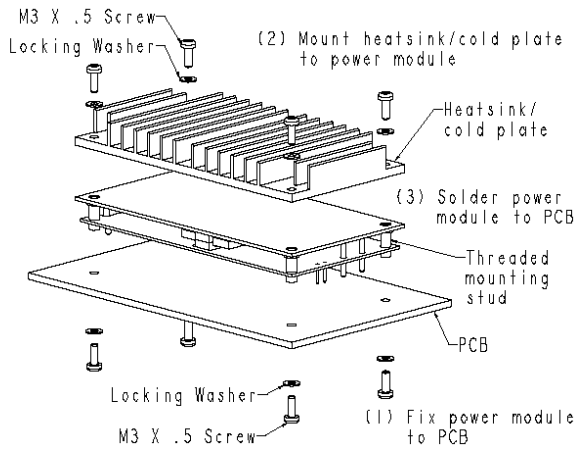

Figure 2 - Assembly Sequence for Threaded Studs

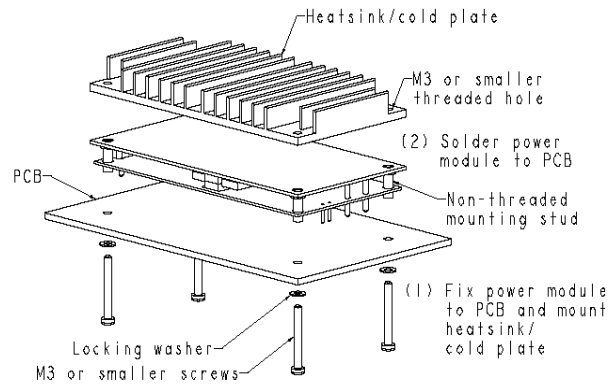

Figure 3 - Assembly Sequence for Non-Threaded Studs

- Torque pattern: Loosely insert all screws before torquing. If the power module has four mounting studs, it is recommended that the torque sequence be in a criss-cross pattern as shown in Figure 4. For modules with only two mounting studs, there is no torque sequence.
- Torque: Screws should be torqued at 0.35 to 0.55 Nm (3-5 inch-lbs). It is recommended that a calibrated torque wrench be used for this purpose.

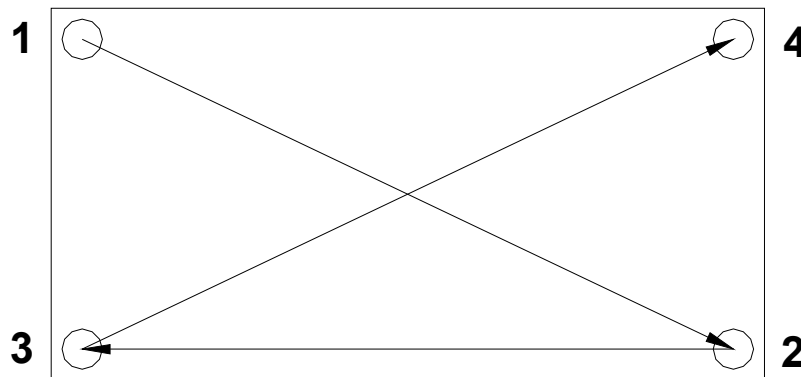

Figure 4 - Torque Sequence

Following the above recommendations and guidelines will ensure that the products are used as designed in full accord with TDK Innoveta warranty conditions.

Further technical help can be obtained by contacting:

support@tdkinnoveta.com

www.tdkinnoveta.com